



Full technical solutions for  
the architectural,  
commercial, broadcast,  
professional audio visual &  
entertainment markets



IT'S ALL ABOUT THE **people**

# The DWR Story

A double garage and a tiny office within a home in Weltevredenpark, Johannesburg, saw the start of DWR Distribution in 2006.

Duncan Riley established the company after a ten-year involvement in the entertainment industry, and needless to say, the initial few months of embarking on a new venture were stressful. Looking back, it's with great thankfulness to God, family and old friends in the industry to see just how far DWR has grown in a short period. Today, DWR is steered by Duncan Riley, Bruce Riley and Robert Izzett. To the team who make up DWR, we appreciate your wonderful attitude.

Once the equipment is sold, whether it's simply "moving boxes" or completing an installation, the service and support relationship begins. DWR strives to serve the industry with dedication and would like to be known as a team that goes the extra mile. The product range covers everything including lighting, audio, LED screens, AV and trussing from supplying rental companies to installing equipment in auditoriums, theatres, houses of worship and where needed.

DWR has premises in Johannesburg and Cape Town, with a dedicated representative in Durban. We have a fully equipped workshop, training facilities and a demo room for a fully immersive experience.

For us, business and life are all about relationships. Thank you to everyone who has helped to make our dream a reality. It's all about the people.

B-BBEE: Level One contributor



IT'S ALL ABOUT THE **people**



## The Install Crew

DWR Distribution is proud to have partnered with Jacob Mogale to form The Install Crew. The Install Crew is a professional specialised electrical installation and maintenance company servicing theatres, studios, schools, houses of worship, commercial markets and residences. Working across South Africa and in neighbouring countries, The Install Crew have built a reputable name for lighting and dimmer installations, electrical maintenance, rewiring and the servicing of existing gear.



## SOS Charity Fund

Established by DWR Distribution in 2017, the SOS is a charity that lends a helping hand to freelancers and technicians who fall ill, are injured or, in the worst-case-scenario, pass away, leaving their family under immense pressure. The SOS has helped to pay hospital bills, purchased grocery hampers, contributed towards funerals and has also been involved in projects that offer hope and inspiration.



## DWR Training

DWR curates a dynamic training calendar brimming with workshops encompassing topics such as lighting, audio, console proficiency, and rigging. Our training sessions frequently showcase distinguished international speakers who provide enriching learning experiences. To keep abreast of DWR's training and event updates, including open days and roadshows, we encourage you to connect with us on our exclusive Telegram Channel. Simply install the Telegram App and join our channel.



IT'S ALL ABOUT THE **people**



## Architectural - retail, museums, exhibitions

DWR has had the privilege of working on many prominent architectural spaces, bringing exterior buildings or gardens to life with washes of colour. Our architectural lighting installations create signature looks and set the mood, as a dark building or structure is transformed into an object of beauty.

*Photo: Mall of Africa in Midrand, Gauteng. Photo by Peter Hassall*



## Theatre - installations and productions

Understanding the precision and demands of theatre, DWR supplies internationally-endorsed equipment, backed up with after-sales support and training. Whether a theatre needs help with rewiring, the servicing of existing gear, a new installation or purchasing new equipment, the team at DWR will assist with passion.

*Photo: War Horse by Brinkhoff*



## Television Studios - installations

From new television studio installations to providing itemised gear, DWR has worked on numerous venues across the country. It is always a great pleasure to be part of the creative team and watch the magic come to life.

training, as always, is provided on new gear.

*Photo: Newzroom Afrika*



IT'S ALL ABOUT THE **people**

# Schools & Tertiary Education Facilities

Educational institutions face a challenging decision when investing in arts-related equipment, seeking reliability for productions that typically occupy only a portion of the school calendar year. Recognizing this, DWR offers guidance on suitable solutions and offers professional and durable gear at cost-effective prices.

*Photo: DWR at The American International School of Johannesburg*

# Houses of Worship

Places of worship, including churches, aim to establish a welcoming and amiable atmosphere where lighting and audio collaborate to effectively convey messages to the congregation. Whether it's in expansive auditoriums or more intimate settings, DWR is well-equipped to provide support with lighting, audio, and AV equipment.

*Photo: Rosebank Union Church*

# Clubs & Venues

Attention to detail is essential for venues and clubs. DWR is able to assist with a full technical package, backed up with service, to compliment your design and clientele. From audio to lighting, whether you have live performances or want to create a warm and friendly atmosphere, the DWR team are able to offer professional advice and assist you to come up with a workable solution.

*Photo: Zioux, Johannesburg*



IT'S ALL ABOUT THE **people**

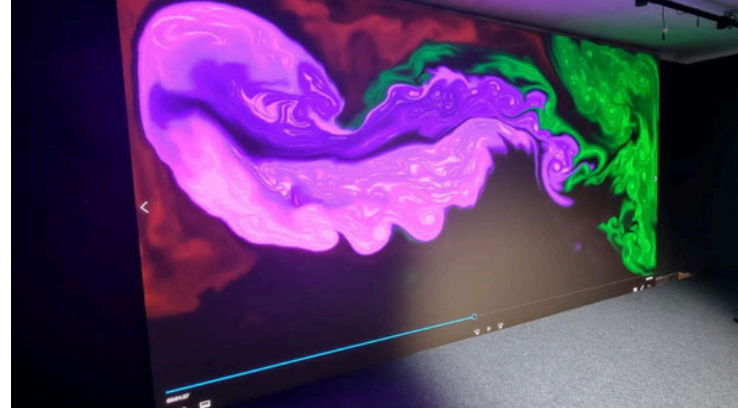

## Pro Audio Visual Integration

DWR is equipped to handle everything from basic meeting room upgrades to complex digital transformation initiatives. Our team and professional equipment ensure successful delivery of audiovisual projects.

We are committed to delivering excellence from project initiation, through to design, implementation, and continuous service and support.

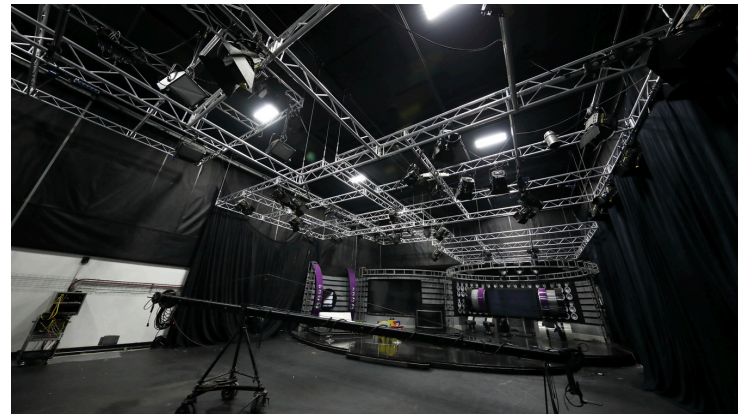

## Manufacturing

Our Metal Fabrication Department will assist you with custom steel and aluminium work for Video Screen Brackets, Custom Brackets, Projector Brackets, Lighting Bars, Patch Bays, Staircases, Base Plates, Top Plates, Trussing Accessories and custom made items.

*Photo: Urban Brew studio upgrade*



## It's all about the people

What sets DWR Distribution apart is our passion for what we do and for being available when our clients need us. Our focus goes beyond products; it's about connecting with people. Our goal is to cultivate meaningful relationships and uphold authenticity in everything we do. The DWR team has evolved into a close-knit family that embrace innovation and creativity, approaching every task with care and commitment.



IT'S ALL ABOUT THE **people**



# ARCHITECTURAL LIGHTING SOLUTIONS

“Light should not interpret architecture; it must transform it! Light should not enhance space and form; it should empower it! Light is the life force of man-made structures. It is through light that events become meaningful.

Light marks our presence as alive and self-aware. Burned in memory, light is profoundly experienced.”

-Edward P. Bartholomew, Professor of  
Architecture



**CALUMMA™ XL SC**

*Lumen output & Light source. LEDs provides up to 10955 lumen output. Multiple LED colour variants. No light spills. Perfectly homogenised light output with efficacy up to 59 lm/w.*



**CALUMMA™ L SC**

*Lumen output & Light source LEDs provides up to 7900 lumen output. Multiple LED colour variants. No light spills. Perfectly homogenised light output with efficacy up to 60 lm/w.*



**CALUMMA™ M SC**

*Lumen output & Light source LEDs provides up to 3478 lumen output. Multiple LED colour variants. No light spills. Perfectly homogenised light output with efficacy up to 57 lm/w.*



**CALUMMA™ S SC**

*Lumen output & Light source LEDs provides up to 1958 lm output (@10°, RGBW). Multiple LED colour variants. No light spills. Well homogenised light output with great efficacy up to 65 lm/w.*



**CALUMMA™ XS SC**

*5.600K daylight LED – Powerful Lumen output & Light source LEDs provides up to 457 lm output (@10°, PW 3000K). Multiple LED colour variants. No light spills. Well homogenised light output.*



**CALUMMA™ XL MC**

*Lumen output & Light source Multi-chip LEDs provides up to 6286 lumen output (@RGBW). Multiple LED colour variants. No light spills. Perfectly homogenised light output with efficacy up to 36 lm/w.*



**CALUMMA™ L MC**

*Lumen output & Light source Multi-chip LEDs provides up to 3970 lumen output (@RGBW). Multiple LED colour variants. No light spills. Perfectly homogenised light output with efficacy up to 36 lm/w.*



**CALUMMA™ M MC**

*Lumen output & Light source Multi-chip LEDs provides up to 2316 lumen output (@RGBW). Multiple LED colour variants. No light spills. Perfectly homogenised light output with efficacy up to 35 lm/w.*



**CALUMMA™ S MC**

*Lumen output & Light source LEDs provides up to 993 lumen output (@RGBW). Multiple LED colour variants. No light spills. Perfectly homogenised light output with efficacy up to 33 lm/w.*



**CALUMMA™ XS MC**

*Lumen output & Light source LED provides light output up to 331 lm (@RGBW). Multiple LED colour variants. No light spills. Perfectly homogenised light output with efficacy up to 33 lm/w.*



AMBIANE™ SP16 RECESSED

*Power balancing feature*

*DMX/DALI*

*Lumen Output & Light Source*

*Wide range of color configurations*

*(RGBW, PW, TW, TD)*

*High Power LED Module CRI 90+*

*Projected lumen maintenance*

*L90B10 >90.000 hrs, Ta = 25°C / 77°F*

*Power Supply (Consumption)*

*44-50V DC (Typ. 10W)*



AMBIANE™ SP16 PENDANT REMOTE

*Lumen Output & Light Source*

*Wide range of color configurations*

*(RGBW, PW, TW, TD)*

*High Power LED Module CRI 90+*

*Projected lumen maintenance*

*L90B10 >90.000 hrs, Ta = 25°C / 77°F*

*Power Supply (Consumption)*

*44-50V DC (Typ. 10W)*



CALUMMA™ REMOTE M MC

*Lumen output & Light source  
Multi-chip LEDs provides up to 2316  
lumen output (@RGBW). Multiple  
LED colour variants. No light spills.  
Perfectly homogenised light output  
with efficacy up to 35 lm/W.*



CALUMMA™ REMOTE M SC

*Lumen output & Light source  
LEDs provides up to 3478 lumen  
output. Multiple LED colour  
variants. No light spills.  
Perfectly homogenised light output  
with efficacy up to 57 lm/W.*



CALUMMA™ REMOTE S MC

*Lumen output & Light source  
LEDs provides up to 993 lumen  
output (@RGBW). Multiple LED  
colour variants. No light spills.  
Perfectly homogenised light output  
with efficacy up to 33 lm/w.*



CALUMMA™ REMOTE S SC

*Lumen output & Light source  
LEDs provides up to 1958 lm output  
(@10°, RGBW). Multiple LED  
colour variants. No light spills.  
Well homogenised light output with  
great efficacy up to 65 lm/w.*

PROMOTION

*Full HD Moving Image & Advertising Projection. Remote  
content management. Fully automated - no site  
intervention required. Lumen Output & Light Source.  
1000 ANSI lumens. RGB LED engine 16.7M colours  
1920x1080 (16:9) - 500:1 Contrast ratio  
Projected Lumen Maintenance  
20,000 hours*



UVINERE™ 2/4

*Almost undetectable luminescence at normal lighting frequencies. Powerful  
output for indoor & outdoor effects.  
Lumen Output & Light Source  
365nm (peak) UV  
16x/32x UV Single Chips  
Projected Lumen Maintenance 10.000 hrs  
Power Consumption  
Typ. 45/85W*



# STAGE LIGHTING

Innovation is about transforming the familiar into the extraordinary.



IBEAM 350  
*All Weather LED Beam*



IESPRITE  
*IP65, Transferable Engine*



IPAINTE  
*IP65, medium throw profile*



ISPIIDER  
*All weather, Wash Beam*



FOOTSIE1  
*IP65-rated footlight & cable tray  
two individually controlled zones*



FOOTSIE2  
*IP65-rated footlight & cable tray  
four individually controlled zones*



ITETRA2  
*IP-65 rated linear bar*



MINI-B SPOT  
*LED-based moving lights*



MINI-B AQUA  
*Weather resistant mini-washlight*



AROLLA PROFILE HP  
*LED Profile moving head*



AROLLA SPOT MP  
*Small, light moving head*



AXCOR BEAM 300  
*Moving LED fixture*



AXCOR SPOT 300  
*Moving LED fixture*



MIDI B  
*Moving LED fixture*



SKYLOS  
*Weather-resistant search light*

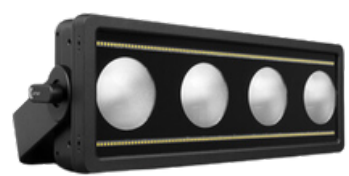

TAMBORA FLASH  
*IP 66 strobe, wash and blinder*



TAMBORA LINEAR 100  
*Hybrid LED bar*



TAMBORA BATTEN  
*Pixel mapping capabilities and unique "three layers" selection*



VOLERO WAVE  
*LED bar with innovative features*



E.SHOW TW+  
*Single-Source LED – Perfect whites and brilliant colors*



E.SHOW FC  
*Single-Source LED – Intense colors & variable white*



E.SHOW T  
*3.200K Tungsten LED – Powerful warm white*



E.SHOW D  
*5.600K daylight LED – Powerful daylight*



E.SHOW MAXX  
*IP65-certified spotlight*



A.SHOW FC  
*Architectural Version  
Single-Source LED – Intense colors & variable white*



A.SHOW FC  
*Architectural Version  
Single-Source LED – Intense colors & variable white*



A.SHOW T  
*Architectural Version  
3.200K Tungsten LED – Powerful white*



A.SHOW D  
*Architectural Version  
5.600K Daylight LED – Powerful Daylight*



E.SHOW MINI TW+  
*Half-sized but packed with power*



E.SHOW MINI FC  
*Full colour (RGLB), LED engine, IP65.*



T.SHOW MINI TW+  
*Tracklight edition RGBALC*



T.SHOW MINI FC  
*Tracklight edition RGLB*



CLUSTER S2

*High-power, pixel mappable hybrid  
strobe / wash*



CLUSTER B2 FC

*Full Color-Lites Blinder*



CLUSTER B4 FC

*Full Color 4-Lites Blinder*



SULLY  
305L

White LED  
Source: 115W  
Lens: 150mm  
Choice of 2 fast-change lenses:  
Pebble-convex / Fresnel



SULLY  
650SX

White LED  
Source: 115W



SULLY  
1156

White LED  
Source: 115W  
Optics: 10.5° - 22.5°



SULLY  
315L 4C

4 Colour LED  
Source: 200W  
Lens: 200mm  
Choice of 2 fast-change lenses:  
Pebble-convex / Fresnel



**LDI**  
2022  
BEST DEBUTING  
PRODUCT LIGHTING

SULLY  
650SX 4C

4 Colour LED  
Source: 200W



ALICE  
1469

LED  
Source: 600W  
Optics: 13° - 24°



OZ  
1169

LED  
Source: 800W  
Optics: 7° - 14.5°



ARTHUR LT  
1014LT

LED  
Source: 800W  
Optics: 4° - 10°



ROXIE2

LED  
Source: 300W  
Optics: 11° - 20°



CRICKET

Tungsten  
Source: 1000/1200W  
Socket: G22 or GY9.5  
Optics: 10.5° - 22.5°



TOPAZE

Discharge  
Source: 1200W MSD  
Socket: G22  
Optics: 7° - 14.5°



CYRANO

HMI  
Source: 2500W  
Socket: SFC 21 - 12  
Optics: 3° - 8°



ZEP2  
664SX

LED  
Source: 300W  
3 Variable zoom options:  
28° - 54°, 16° - 35° and 11° - 26°



ZEP2 FRESNEL  
360LF2

LED  
Source: 300W  
Lens: 200mm  
Fresnel



CYCLIGHTS  
DALIS ACCESS 863

LED Cyclight  
Source: 150W  
4 Colours



SPOTME

Real time tracking for  
followspots



S4 LED SERIES 2

*With the brightest output and the boldest rendering of the colors you use most, the Source Four LED Series 2 introduces a whole new level of LED ellipsoidal lighting fixtures that can be used anywhere.*



S4 LED SERIES 3

*A spotlight for every location Revolutionary color mixing with unparalleled brightness for every location in your theatre.*



COLORSOURCE PAR

*Washlight Workhorse. An LED luminaire crafted by lighting experts, the ColorSource PAR uses a balanced recipe of red, green, blue, a twist of lime, and an extra dash of red to provide a richness of color only possible from ETC LED luminaires.*



COLORSOURCE SPOT V

*An LED luminaire crafted by lighting experts with a proven history of quality spot fixtures, ColorSource Spot V brings a richness of color, increased brightness, and leading technology at a price point you'll love. Featuring a five-color array of red, green, blue, indigo, and lime, the ColorSource Spot V provides soft pastels and bold saturated colors from a single fixture.*



COLORSOURCE FRESNEL V

*Five-color array (red, green, blue, indigo, and lime); Motorized 13-44° degree zoom with DMX and local control.*



SOURCE 4WRD COLOR II

*The Source 4WRD Color II LED engine transforms your existing Source Four incandescent profile into an RGBA LED fixture, unlocking the world of additive color mixing, saturated washes, and quick color changes.*



SOURCE 4WRD II

*For over 25 years, Source Four has been synonymous with theatrical lighting. Keep those fixtures but move 4WRD with the high output but perfectly nuanced LED lighting of the Source 4WRD II.*



ARCLAMP



ARCSYSTEM PRO ONE-CELL



ARCSYSTEM PRO FOUR-CELL PENDANT



ARCSYSTEM PRO MULTI-CELL



BLUEDOME



BLUEDOME



PARADIGM FAMILY FACILITY-WIDE LIGHTING CONTROLS



MOSAIC LIGHTING CONTROLS FOR DRAMATIC EFFECT



ECHO ENERGY EFFICIENT, WIRED ROOM CONTROLS



VARI\***LITE**



CANTATA LED FRESNEL

The Cantata LED Fresnel Full Color (FC) is a modern LED theatrical Fresnel designed for midsized applications. This full color luminaire uses an RGBALC (Red, Green, Blue, Amber, Lime & Cyan) color mixing system for a wide mixable color spectrum, but it can be easily controlled with traditional CYM controls.



LEKO LED PROFILE

The Full Color profile luminaire uses an RGBALC (Red, Green, Blue, Amber, Lime & Cyan) color mixing system for a wide mixable color spectrum.



AURORA LED STRIP

The Aurora LED Strip is a high output theatrical strip luminaire that provides rich color mixing for multiple applications around the performance stage, including set piece illumination, graze / cyc lighting, foot lighting, and more.



CODA LED CYC

The Coda LED Cyc is a high output theatrical cyc luminaire that provides rich color mixing for seamless coverage of a stage's cyclorama.



ACCLAIM LED ZOOMSPOT

A successor to the iconic Acclaim, this LED zoomspot luminaire offers high output and full color mixing in a single, cost-effective fixture designed for precision key lighting and gobo projection. Built-in manual zoom and focus and a four-blade manual shutter system



ACCLAIM LED FRESNEL

The Acclaim LED Fresnel is a full color theatrical Fresnel wash fixture designed specifically for small to medium spaces.



ACCLAIM LED CYC

A breakthrough in cyclorama lighting, the Acclaim LED Cyc luminaire delivers smooth even cyclorama lighting in a compact lightweight design. Using just 145 watts of power to illuminate drops up to 5 meters high each unit can replace the equivalent of a traditional 4 color 500 watt luminaire.



#### VL5LED WASH

*The Vari-Lite VL5LED WASH is a true modern update to the legendary VL5. This compact, high output LED wash fixture brings a host of modern features to the familiar form factor of this unique fixture. The Dichro\*fusion® blades, first seen in the VL6500 WASH, supply smooth, variable diffusion while the RGBALC color system provides a wide range of rich color options.*



#### VL3600 PROFILE IP

*The Vari-Lite VL3600 PROFILE IP is a large-scale, high output production profile fixture designed to withstand inclement weather without compromising on weight and size.*

#### VL1600 PROFILE

*For a wide color range and maximum flexibility, the Vari-Lite VL1600 PROFILE combines a high-definition tunable white LED source with CMY color mixing. The tunable white engine lets designers can achieve warm and cool light from a single luminaire without sacrificing output or CRI, along with a wide range of colors from subtle pastels to bold saturated colors.*



#### VL6000 BEAM

*A large 14" front aperture – using a new exclusive Vari-Lite ellipsoid reflector array system – produces a retro style searchlight effect, with a high output tight collimated shaft of light at 6.5°, which exceeds 55,000 lumens.*





STUDIO LED X1 PLUS  
BI-COLOR - LED FRESNEL 35W



STUDIO LED X2 PLUS  
BI-COLOR - LED FRESNEL 60W



STUDIO LED X3 PLUS  
LED FRESNEL 100W DAYLIGHT



STUDIO LED X5 PLUS  
LED FRESNEL 200W DAYLIGHT



STUDIO LED X4 PLUS  
LED Bi-color Fresnel range for  
broadcast and studio applications.



STUDIO 2KW TUNGSTEN  
*The STUDIO range has been developed specifically for Film and TV applications where there is a need for high-quality and balanced output producing flat and very even field.*



INFINITY 100  
LED PANEL 90W BI-COLOR.  
*ideal for TV studios where the ceiling is very low.*



INFINITY 200  
LED PANEL 180W BI-COLOR. *The INFINITY 200 is 180W and it can be used for normal and high-ceiling TV studios where it is required a high level of illumination and power to light up the entire structure.*





**PLUTOFRESNEL**  
*Battery-powered RGBMA fresnel, 80W, CMX, wired DMX..*



**LEOFRESNEL**  
*Battery-powered RGBMA fresnel, CRMX, Wired DMX, 250W.*



**TITANTUBE**  
*LED tube. 48W, RGBMA, 16 Pixels, Wired DMX, CRMX.*



**HELIOS TUBE**  
*Shorter tube. 24W, RGBMA, 8 Pixels, Wired DMX, CRMX.*



**PIXELBRICK**  
*Multi-purpose uplight with the ability to build shapes. RGBMA, 15W, CRMX, wired DMX.*



**AX2 PIXELBAR**  
*LED Bar with built-in battery. RGBMA, 160W, 16 Pixels, CRMX, Wired DMX.*



**HYDRAPANEL**  
*Small LED panel for flexible film & studio illumination. RGBMA, 6 pixels, 17W, CRMX, wired DMX.*



SNAPBAG

*For one HydraPanel including 2  
Diffusion and Carry bag*



SNAPBAG

*For 4 HydraPanels including two  
diffusions (half gride& magic cloth)  
and carry bag.*



SNAPBAG

*For 4 HydraPanels including two  
diffusions (half gride& magic cloth)  
and carry bag.*



F4 UP

*Indoor parcan, 180W,  
full RGBW LED*



F6

*Wash, 200W,  
full RGBW AWUV LED*



F8

*92W, Full ACW LED. Die cast  
body, same size as traditional  
Par64,*



EXCELSIOR BAR.

*184FRGBW  
waterproof LED wall wash*



PHOENIX 300 BAR

*LED Source, 360W, full RGBW  
LED, colour mixing.*



EDEN QUAD7

*Outdoor parcan.  
60W, full RGBW LED*



PARCO R350 (IP RATED 4UP)

*Outdoor parcan.  
120W, full RGB.*



**TASK LIGHT - L-18 LED**  
L-12A-LED 12 inch (30.48 cm) gooseneck  
L-18A-LED 18 inch (45.72 cm) gooseneck



**ANSER DESK LIGHT - DL4**  
The ANSER uses a single, warm white LED coupled with our new CC (Constant Current) dimming circuitry in a lineal (end-out) gooseneck configuration. The result? Massive light output in a svelte, easy to position gooseneck assembly.



**ANSER-DUAL LED**  
Originally designed for microscope illumination, the DUAL ANSER is also an excellent choice for any application requiring strong, even illumination. The two gooseneck LED lights can be positioned to illuminate from multiple sides eliminating shadows.



**18XR-4-LED CONSOLE LIGHT**  
Littlite XR-4 Series console lights configured for the MIDAS PRO2 series audio consoles. 18XR-4-LED ML for left side of PRO2. Important Note!: The Littlite PRO2 series lights are configured for the first generation PRO2 consoles. Later generations may have different XLR panel socket orientations and require the pin inserts in your Littlites to be rotated to match.



**RL-10-S - RACKLITES, PERMANENTLY ATTACHED**

Even illumination with precise color depiction with the help of single 12" (30.48 cm) high intensity gooseneck lamp. The Colorfade dimmer allows you to control the brightness and the gooseneck allows you to focus light exactly where required. Designed for standard 1 RU rack installation, the LED is suitable for pro audio and A/V rack applications.



**RL-10-D LED - RACKLITES, PERMANENTLY ATTACHED**

The Littlite RL-10-D-LED Dual Gooseneck Lamp comes with a mix of red and white LEDs that ensure precise color rendering and uniform illumination.



**LA-18LED LECTERN LIGHT**

The Littlite LA series lectern light is designed for a sleek looking installation. Detachable TNC mount 12" gooseneck. Mounting screws and drilling template included.

Littlite LA-18A-LED Features

- Red/White LED Array Circuit Board
- 12-Volt Operation
- Detachable Gooseneck (TNC Connector)
- Flush Mount Bracket with Dimmer

- zactrack mini Master Anchor  
(incl. power supply)

- 4-in-1 uses - Master Anchor, Server, Wireless Access Point & DMX Node
- Up to 64 Fixtures
- 6.24 - 6.74 GHz UWB active radio antenna
- 190 x 207 x 36mm, 680g, IP50
- Neutrik etherCON RJ45, Neutrik XLR 5 pole & USB-C - Port
- 3 hours battery life, 3 hours charging time (100%)
- Rig mounting plate for clamp and safety line

- zactrack mini Tracker

- 6.24 - 6.74 GHz UWB active radio emitter
- 35 x 60 x 10mm, 26g, IP65
- up to 5 active Trackers (16 Hz)
- up to 15 active Trackers (6 Hz Audio only)
- up to 60 inactive Trackers
- 4 hours battery life (active), 20 hours battery life (inactive), 2 hours charging time (100%)

- zactrack USB-C Power supply  
(EU/UK/US/AUS)

- zactrack Tripods

- 6x 1/4" inch thread tripods for screwing attachment

- zactrack mini Kit - Case

- all required zactrack mini components can be stored in the briefcase sized case for easy transport and deployment by one person

- zactrack mini Anchor  
(incl. power supply)

- 5 Anchors to mount around the stage
- 6.24 - 6.74 GHz UWB active radio antenna
- 140 x 140 x 35mm, 290g, IP54
- USB-C - Port
- 16 hours battery life, 2 hours charging time (100%)
- Rig mounting plate for clamp and safety line

- zactrack mini Charging station  
(incl. USB-C cable)

- Charging station for Trackers (5 slots)
- 270 x 70 x 70mm, 390g
- USB-C - Port



● zactrack SMART Server

- 1 server up to 64 active fixtures
- 2 servers up to active 256 fixtures + backup
- 9.5" (half size) rack mount server
- 222 x 34,5 x 230 mm, 1 HU, 1320 g
- 230 VA with Input 100 - 240 Vac, 50 - 60 Hz

● zactrack SMART Anchor

- from 8 up to 11 anchors around the stage
- 6.24 - 6.74 GHz UWB active radio antenna
- 190 x 200 x 42 mm, 535 g, PoE, IP 54
- Rig mounting plate for clamp and safety line

● zactrack SMART Tracker

- 6.24 - 6.74 GHz UWB active radio emitter
- 35 x 60 x 10 mm, 26 g, IP 65
- 8 hours battery life
- up to 10 active trackers (16 Hz)
- up to 30 active trackers (6 Hz Audio only)
- up to 60 inactive trackers

● zactrack SMART Puck

- Use 4 Pucks for anchor calibration & fixture alignment (black, red, green & blue)
- 6.24 - 6.74 GHz UWB active radio emitter
- Lighting Sensor
- 95 x 95 x 59 mm, 342 g, IP 54
- 24 hours battery life
- USB-C for charging (cable included)
- (Standard 5V USB charger is not included)

● zactrack SMART Charger

- Charging station for trackers
- 270 x 70 x 65 mm, 387 g
- 5 charging slots for each charger
- USB-C for charging (cable included)
- (Standard 5V USB charger is not included)

● zactrack SMART Accessories

- Server Coupler (couple 2 servers to 19")
- Server 19" Extension (extend 1 server to 19")





- zactrack PRO Anchor
  - 4.25 - 4.75 GHz UWB (ch3) active radio antenna
    - 190 x 200 x 42 mm, 535 g, PoE, IP 64
  - Rig mounting plate for clamp and safety line
  - Power supply: PoE (48V) - Neutrik etherCON

- zactrack PRO Alignment Puck
  - Lighting Sensor
  - 95 x 95 x 35 mm, 200 g
  - 12 hours battery life (2x AA Batteries)

- zactrack PRO Tracker
  - 4.25 - 4.75 GHz UWB (ch3) active radio emitter
    - 47 x 33 x 7,5 mm, 15,4 g, IP 54
    - 4,5 hours battery operating time
  - Charging Time: 2,0 hours (100%), 5V DC

- zactrack PRO Charger
  - Capacity for 30 transmitter
  - 295 x 235 x 20 mm, 1 kg
  - Power supply: DC 24V / 2A



DOUBLE DUTCH DOME  
*2 for 1. Use as a Rainroof or Dome*



RAINROOF MINI



RAINROOF SMALL



RAINROOF MEDIUM



RAINROOF LARGE



RAINROOF XL



SMALL AIRDOME



LARGE & XL AIRDOME



MDG ATME  
*Haze generator*



LEMAITRE MVS HAZER  
*Geared towards small to large sized venues*



ANTARI HZ-500  
*Hazer*



ANTARI HZ-350  
*Hazer with LCD control panel.*



# LIGHTING CONTROL

An effective lighting design is like a beautiful painting.

*Photo: 2023 Eurovision Song Contest. Copyright Corinne Cumming*



### GRANDMA3 FULL-SIZE

*20 Physical playbacks and 16 assignable x-keys,  
20 480 control parameters as standard*



### GRANDMA3 LIGHT

*Featuring 60 physical playbacks, 16  
assignable x-keys and a dedicated  
master area*



### GRANDMA3 COMPACT XT

*With 60 physical playbacks, 16  
assignable x-keys and a dedicated  
master area the grandMA3 compact  
XT console provides plenty of  
playback options.*



### GRANDMA3 ONPC 4PORT NODE DIN-RAIL 4K

*DMX Node. Convert Ethernet data to DMX or add parameters to  
your grandMA3 onPC system.*



#### LSC MANTRA LITE

*suited for all types of operators in small theatres,  
places of worship and entertainment venues.*

#### LSC MANTRA LITE WING

*IP65, medium throw profile*



#### ZERO88 FLX S24

*24 Fader lighting control surface*



#### ZERO88 FLX S48

*48 fader lighting control surface*

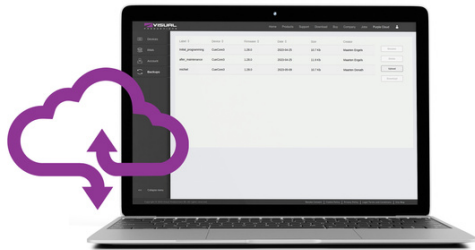

PURPLE CLOUD  
REMOTE MANAGEMENT

*The cloud-based approach allows you to easily access & manage your lighting system from anywhere in the world, giving you unprecedented control and visibility over your operations.*



CUECORE3

*Powerful architectural lighting controller*



CUECORE2

*Multi-protocol architectural lighting controller*



IOCORE2

*The IoCore2 is a network-based solid-state interface for GPIO signals. It features eight GPI ports that can be configured as digital contact-closures or analog 0-10V level inputs.*



B-STATION2



KIOSC

*Kiosc is an application for creating custom touch screen user-interfaces for the Visual Productions' range of lighting controllers.*



DALICORE

*DALI and DMX hybrid controller*



TIMECORE

*The TimeCore is a compact device that can perform all tasks related to timecode. It can generate, follow, convert and display timecode signals. It even handles a number of non-timecode protocols.*



### EDMX1 MAX1

*Compact and robust this single universe Ethernet DMX512 node suits a wide range of applications.*



### EDMX4 MAX

*Rugged 4 port DMX512 node. Fully protected and isolated DMX512 IN/OUT independently configurable ports with advanced stream merging and built in show recording for standalone operation.*

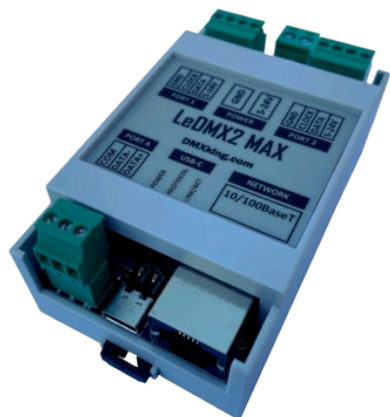

### LEDMX2 MAX

*Direct sACN/E1.31 and Art-Net to RGB/RGBW pixel strip/array control with built in show recording for standalone operation. The most sophisticated feature packed pixel controller on the market.*

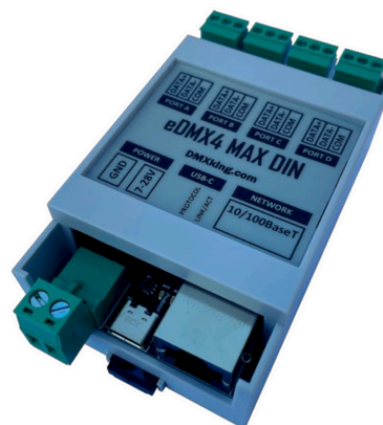

### EDMX4 MAX DIN

*The most compact 4 port sACN/E1.31 and Art-Net to DMX512 node available. DMX512 IN/OUT independently configurable ports with advanced stream merging and built in show recording for standalone operation*



### LEDMX 4 MAX

*Direct sACN/E1.31 and Art-Net to RGB/RGBW pixel strip/array control with built in show recording and external triggering for standalone operation.*



STARDUST

*Eight Universe DMX/RDM transmitter with Ethernet and WiFi*



AURORA

*Single Universe DMX/RDM transceiver with WiFi and Bluetooth.*



LUNA

*Single Universe DMX transceiver with Bluetooth.*



MOONLITE

*Rechargeable DMX/RDM transceiver with Bluetooth.*



GALILEO RX

*Single Universe DMX/RDM Receiver*



GALILEO TX

*Single Universe DMX/RDM Transmitter*



CRMX OUTDOOR FLEX

*Single universe CRMX transceiver with RDM*



CRMX SLIM

*Single universe CRMX receiver with RDM*



CRMX SLIM RX RDM

*Single universe CRMX receiver with RDM and DALI*



CRMX SLIM

*Single universe CRMX transmitter with RDM and DALI*

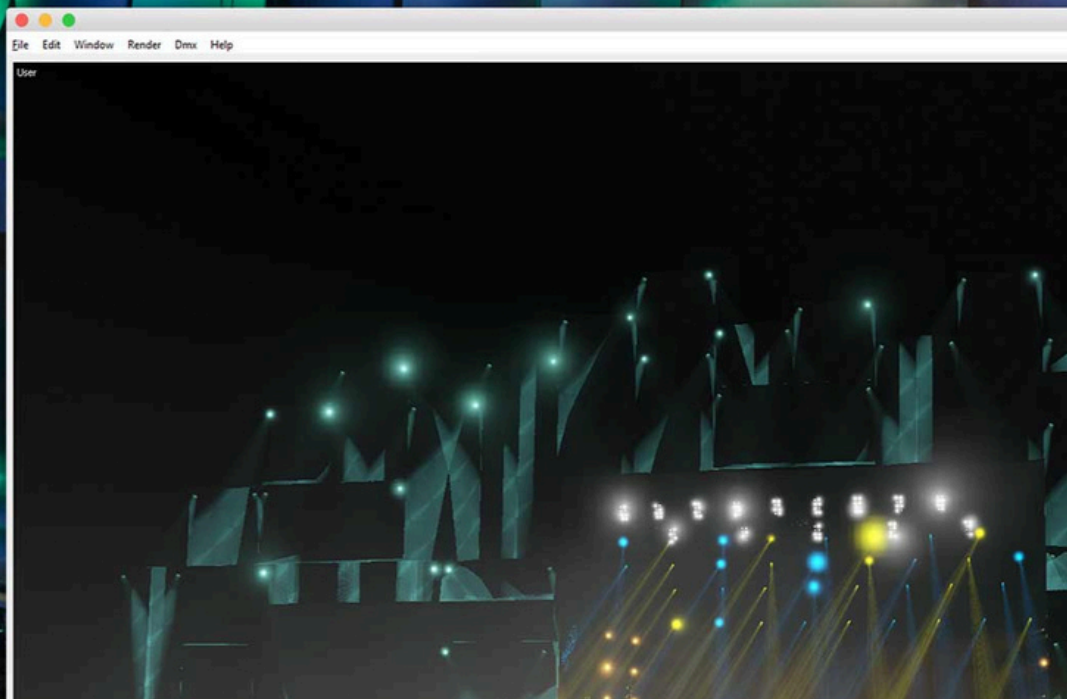
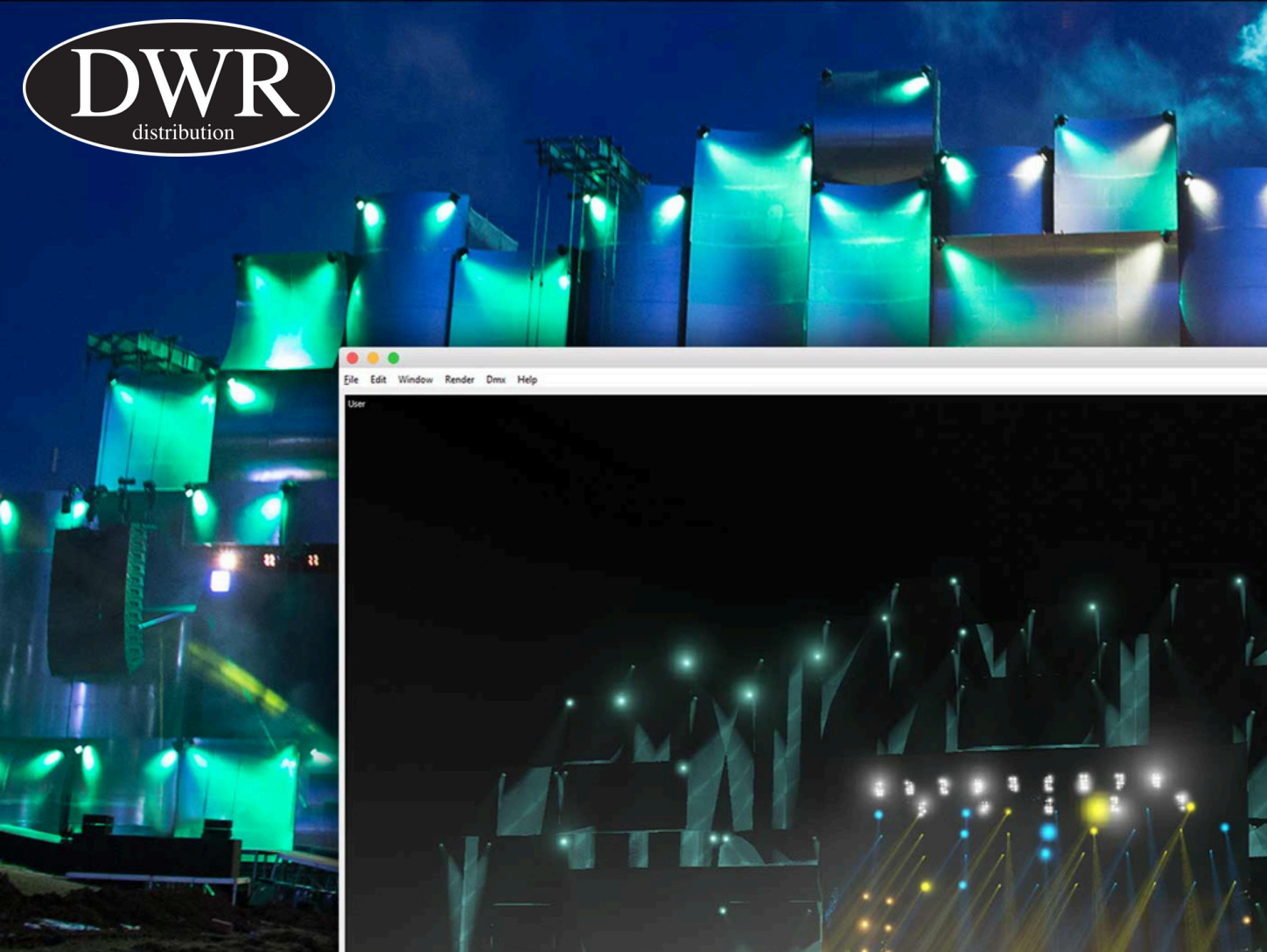

Santuário São Paulo.pdf

5:38 PM

30%

VECTORWORKS  
A NEMETSCHEK COMPANY

33.93%

ProoF of Load Capacity

FD34

Maximum influence line values

The following table shows the maximum influence line values for each position and sectional workload.

Beam @ distance	Max. influence line values	Nx	Vy	Vz	Mx	Myy	Mzz
-	Nx	0.00 czf	-	-	-	-	-

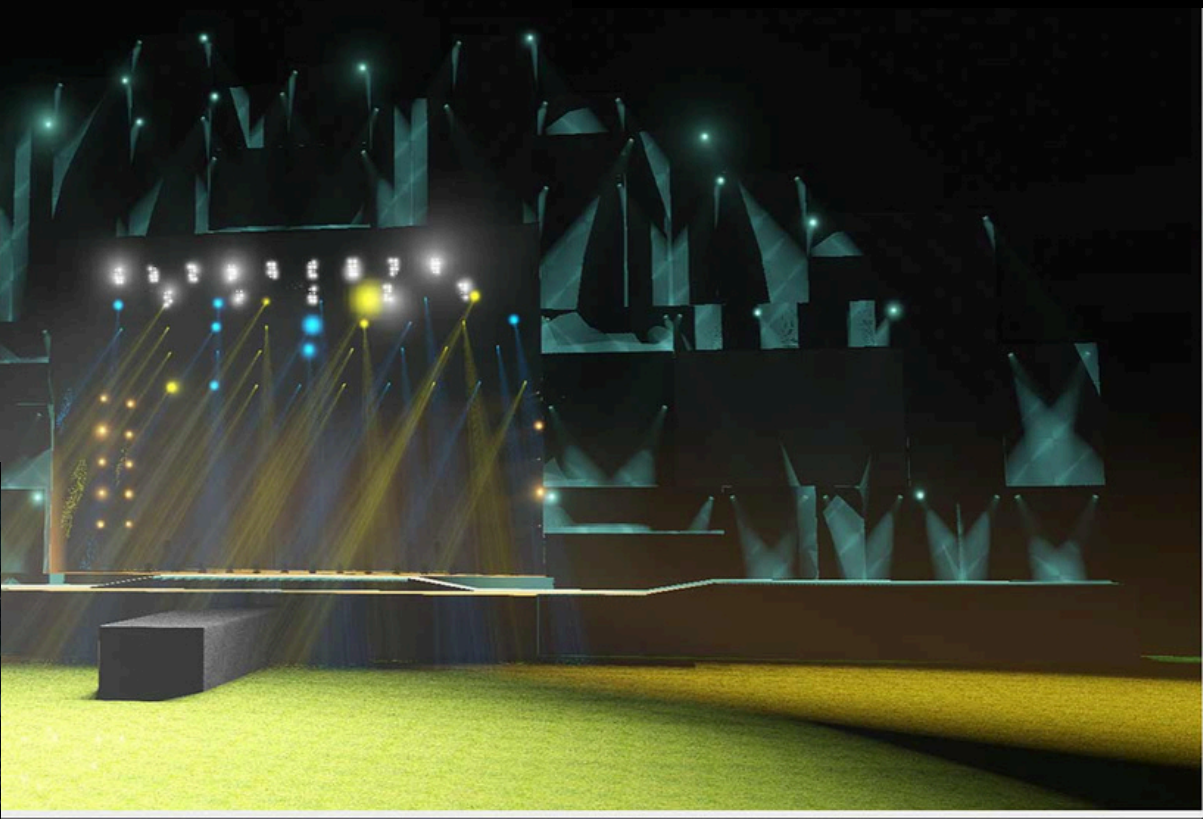



*Vectorworks cares about design. Whether you work in lighting, scenic, film, event, or exhibit design, Vectorworks is the only solution with the flexibility to support your entire process. Spotlight will assist with precision drawing, creative modeling, reports, coordination, graphics and presentations, analysis with Braceworks and Previz with Vision.*

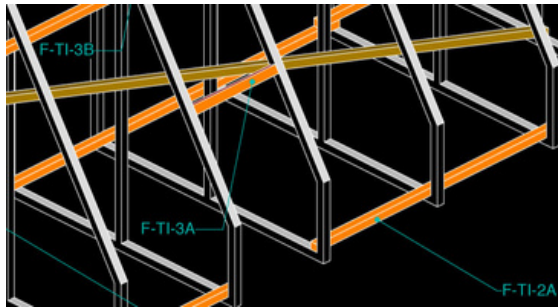

PRECISION DRAWING

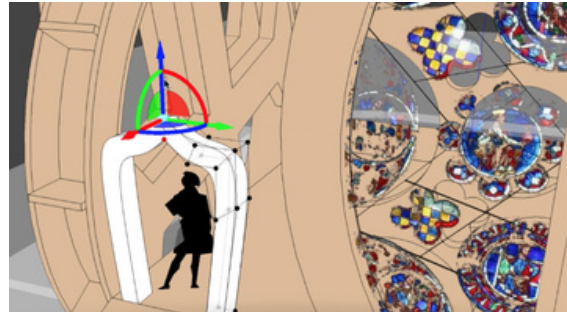

CREATIVE MODELING

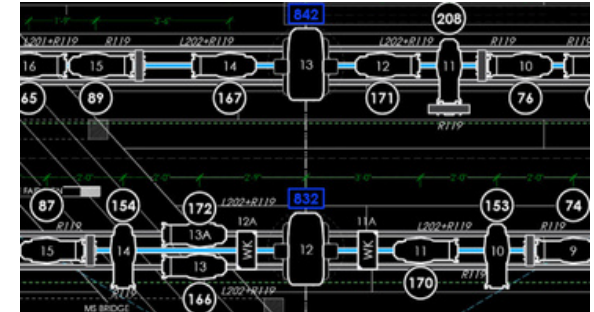

REPORTS & COORDINATION

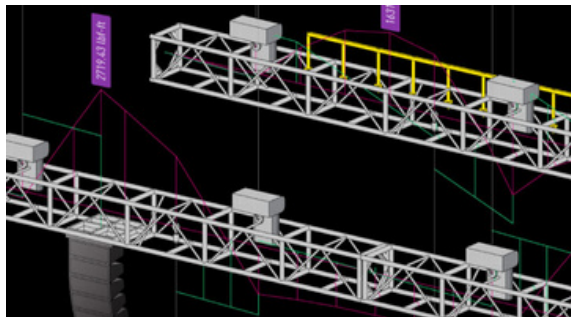

ANALYSIS WITH BRACEWORKS



PREVIZ WITH VISION

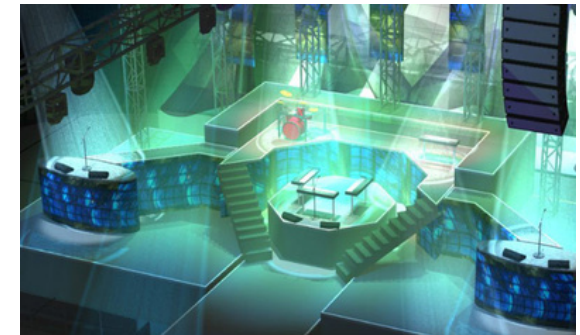

GRAPHICS & PRESENTATION

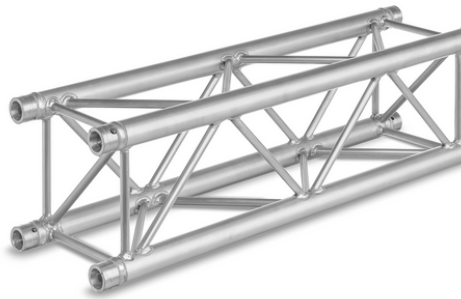

### H30V SQUARE TRUSS

*main chords (48 x 3 mm) and diagonal members (16 x 2 mm)*

*Length: 0.25m to 4m length and custom lengths available*

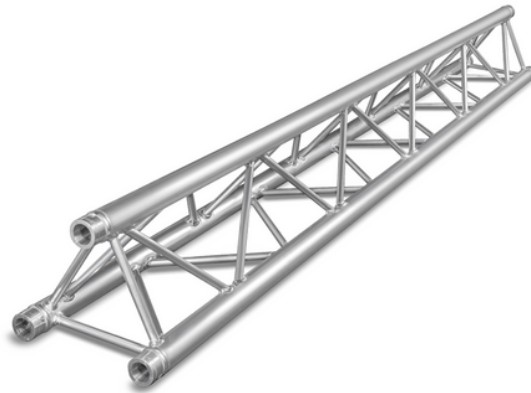

### X30D TRIANGULAR TRUSS

*51 x 2 mm) & diagonal members (16 x 2 mm)*

*Length: 0.25m to 4m length and custom lengths available*

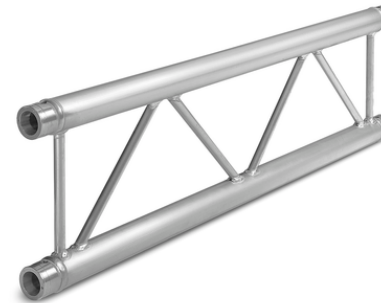

### X30 LADDER TRUSS

*(51 x 2 mm) and diagonal members (16 x 2 mm)*

*Length: 0.25m to 4m length and custom lengths available*

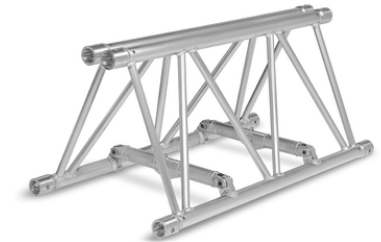

### S52-FOLDING TRUSS

*The S52 truss offers a strong truss with a very high loading capacity; the S52SV has a 4-sided webbing, making it strong in a vertical and horizontal plane. The folding truss offers low transport volume combined with ultimate strength. S52F truss is not available as circular truss.*



### H40V-MB (MIDDLE BEAM)

*H40 MB Series square truss is constructed of main chords (48 x 3 mm) and diagonal members (20 x 2 mm). Equipped with the CCS6 conical coupling system, the H40 MB truss is fast and easy to assemble. The H40 offers extra strength, next to its flexible application possibilities and is the ideal solution for the event or exhibition market*

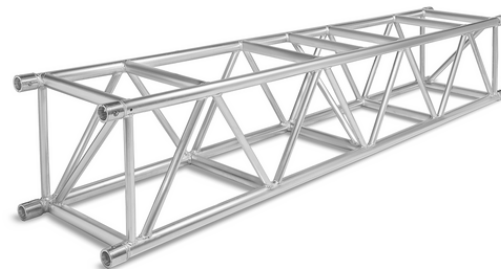

### S52V

*52 Series Square truss is constructed or main chords (50 x 4 mm) and diagonal members (25 x 3 mm - 30 x 3 mm). Equipped with the CCS7 conical coupling system, the S52 truss is fast and easy to assemble. The S52 truss offers a strong truss with a very high loading capacity.*



### BOX CORNER 40R HD

*The new box corner, the BOX-40R-HD, is a fully plated and bolted element and therefore much stronger than the regular box corner. This allows you to build any 2D or 3D structures without losing involuntary strength due to the corner types used.*



STAGE DEX 2 X 1M

*StageDex can be qualified as the best and most versatile staging system available. The StageDex TopLine deck is a high quality, lightweight deck, offering a birch plywood surface, with water resistant and anti-skidding qualities.*



TOPLINE DECK 1X0.5M

*The TopLine deck has a reinforced corner, offering a standard spigot entry on the topside of the deck. All decks have a loading capacity of 750kg/m<sup>2</sup> and are available in metric and imperial sizes and different shapes.*



ARC ROOF

*The Arc Roof is a fixed construction, based on three inward-curving trusses that are mounted to side masts. Special corners connect the arches to the main grid. Different configurations are made possible by simply changing the arches. The arched trusses have a keder profile on top for fitting the optional canopy.*



MPT ROOF

*The MPT Roof is a tower-based structure with a pitched roof, a design which guarantees optimum strength. Primarily configured from standard trusses, the MPT Roof is available in three different sizes. However, the unrivalled flexibility of the system affords nearly 40 calculated building varieties or setup possibilities for your MPT Roof.*

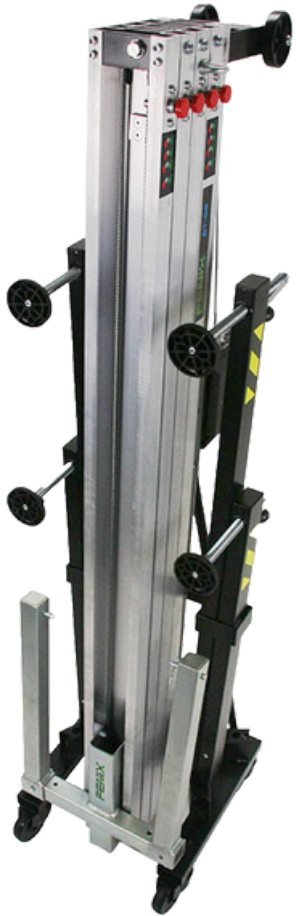

AT-06

Frontal loading lifting tower. AT Series allows you to lift loads from the floor, reducing user effort.

Uses: The AT Series is perfect to lift line array systems, can also raise trussing and LED screens.



ELV-230/5

Telescopic lifting tower. ELV Series towers have a special 'outrigger' system that can work almost anywhere. Its leg tensioners allow installation at any angle, resting securely on any surface. The swing-arm plates guarantee stability of the tower.



HERCULES 6.5 PLUS

Super frontal loading lifting tower. HERCULES Series, powerful and easy to use. Uses: For lifting line array systems, trussing or LED screens.





## D8 - ELECTRIC CHAIN HOISTS

*The compact form, robust aluminium casing and low unladen weight of CHAINMASTER rigging lifts guarantee optimal handling in day-to-day use. An extensive selection of optional fittings and accessories allow worldwide use in line with the widest range of requirement criteria. In combination with CHAINMASTER control systems, we can offer all users – even for special applications – an all-in-one solution that leaves nothing to be desired.*

320kg; 500kg - 12 000kg



## D8PLUS - ELECTRIC CHAIN HOISTS

*Increased safety, flexibility and efficient rigging for complex loads are the main features of D8Plus chain hoists.*



## U-LIFT

### Product Features

- Up to 45% lighter compared to other devices of this load capacity
- Reinforced safety catch for suspension and load hooks
- Mostly enclosed aluminium housing
- Chain guide ensures a safe and guided feed-in of the chain
- Including chain bag and 10m lifting height



For the past 40 years Eilon Engineering has specialised in the development and manufacture of state-of-the-art products, based on the latest technologies, including Ron crane scales, dynamometers and load cells.

In 2006, Eilon Engineering decided to harness its extensive knowledge in advanced wireless communication, as well as its proven load cell technology, for the development of an advanced multi-point load Eilon Ron StageMaster Portable Radio Receiver Ron Stage Master 6000 G4 Wireless - monitoring and overload prevention system. This was the inception of the Ron StageMaster™ system, which, shortly after its launch, gained international recognition as well as innovation awards at both LDI and PLASA.

Ron StageMaster is used worldwide for stage applications, but it is also for complex, heavy lifting where load monitoring in multiple lifting points is crucial, known as Ron CraneMaster.



RON STAGEMASTER  
6 000 G4 WIRELESS-  
EILON CLASSIC



LOAD CELL NEW  
GENERATION

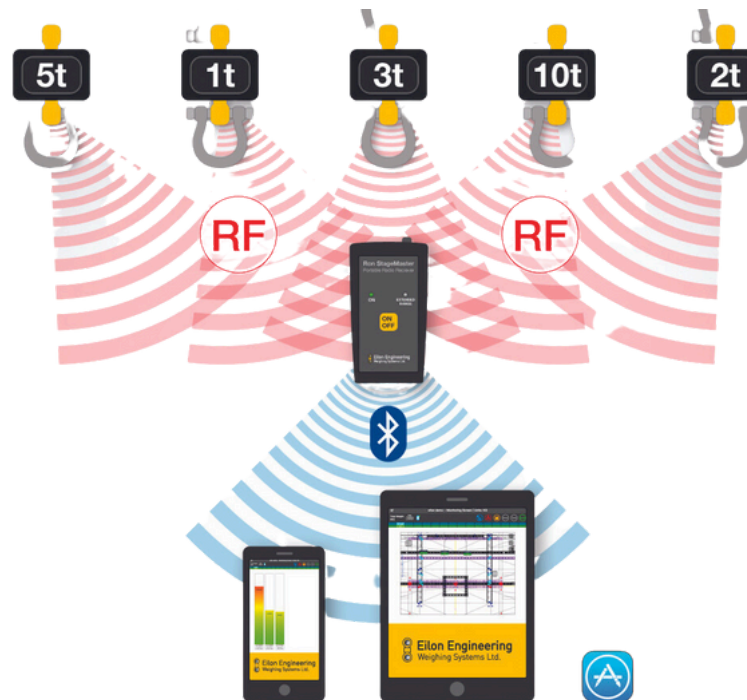

EILON RON  
STAGEMASTER PORTABLE  
RADIO RECIEVER

**Ron  
StageMaster** by  
Eilon Engineering  
Weighing Systems Ltd.

The ASM product range covers the entire spectrum of applications for point hoists, scenery hoists and stage light hoists. The company's philosophy of innovation is reflected in its numerous patents and its specialisation in providing customised system solutions for all stagecraft needs.



#### GENESIS CONTROL

The remote control of the GENESIS system allows complete control of all hoists by holding it easily in the operators hand. For maintenance purposes, a single hoist can be controlled directly.



#### CONTROL DESK CD

The Control Desk series is the interface for safe and reliable hoisting of equipment via the powerful GENESIS software. All Powerpacks (drives) control ASMs full range of hoists and most third party hoists.



#### CONTROL DESK CD

The Control Desk series is the interface for safe and reliable hoisting of equipment via the powerful GENESIS software. All Powerpacks (drives) control ASMs full range of hoists and most third party hoists.

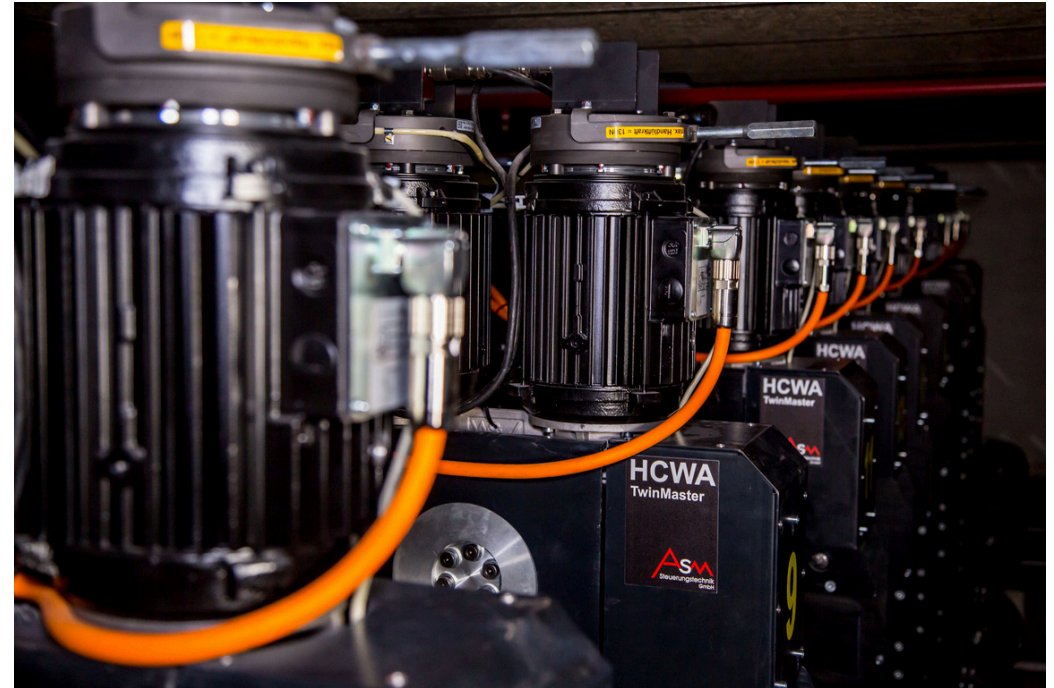

#### HCWA TWINMASTER

The HCWA TM HD is the heavy-duty hoist of the TwinMaster range, most suitable for heavy duty applications in theatres such as lifting lighting bridges, led walls or acoustical shelves. The HCWA TM HD safely moves heavy loads of up to 2,000 kg with a speed of up to 0.6 m/s. This heavy-duty hoist comes in a standard in two version one with 6 mm ropes and one with 8 mm ropes. In double-reeved operation the TwinMaster HD lifts loads up to 4.000 kg.



REUTLINGER CABLE  
QUICKTRIGGER WITH  
FIFTY CLAMP HOLDER  
80 SVII



QUICK TRIGGER WITH  
HALF CONNECTOR



FIFTY CLAMP



TWENTY CLAMP



MAMMOTH HOOK CLAMP



KCP 830



KCP 830B



KCP 844 TV COUPLER



KCP 844B TV COUPLER



KCP 820 SWIVEL  
COUPLER



KCP 820B SWIVEL  
COUPLER



KCP 832ST STAINLESS  
STEEL



KUPO MASTER  
COMBO HD STAND



# AUDIO

No one ever goes home  
humming the lights



A10  
*1/1 Performance and discretion  
2-way passive, 10"*



A15  
*Performance and simplicity  
2-way passive, 15"*



A10  
4/4



LA4X  
*Amplified controller*



X12  
*Jack of all trades, 2-way passive, 12"*



X41  
*2-way passive, 4"*



X15 HIQ  
*2-way active, 15"*

Medium throw ▶ A Series



# A10 - A10i

## PERFORMANCE AND DISCRETION

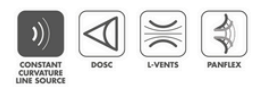

A10(i) associated product: **KS21(i)**

The compact size and lighter weight of A10 make it ideal for applications with visual constraints. On its own, A10 combines optimal bandwidth and clarity for vocal reinforcement or light music, producing an ideal SPL to-size ratio to complement a larger system as fills. On a stick, stacked or flown, vertically or horizontally, as a single enclosure or in a line source arrangement, A10 fits into any venue.

A single preset for both Focus and Wide models combined with the adjustable directivity, offers easy performance and unlimited adaptability. Boasting a high SPL-to-size ratio, A10 can be coupled with the KS21 subwoofer for events requiring broader bandwidth and larger contour.

A10i is the install version with streamlined rigging and a custom color palette for installations calling for architectural discretion.



Rooftop Party: Don't Let Summer Die at Nashville Underground – Nashville, TN, USA



Deployment examples for A10 rental (brown) and A10i installation (white)

Medium throw ▶ A Series



# A15 - A15i

## PERFORMANCE AND SIMPLICITY

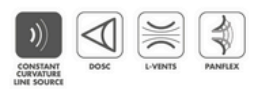

A15(i) associated product:  
**KS21(i)**



A15 was designed to provide the bandwidth and contour of a large format line source system in a simple and ultra-scalable solution for medium throw applications. As a speaker-on-a-stick, stacked or flown with the companion KS21 subwoofer, vertically or horizontally, A15 scales to any application from 50 to 5,000 people. A15 delivers our renowned concert performance and reliability in a multi-purpose system fast to deploy and offers unparalleled flexibility.

A single preset for both Focus and Wide models facilitate connectivity, offering easy performance. While adjustable directivity, combined with sophisticated optimization tools in Soundvision, gives A15 unlimited adaptability.

A15i is the install version with streamlined rigging and a custom color palette for installations calling for architectural discretion.



Deployment examples for A15 rental (brown) and A15i installation (white)

Small Corporate / Small Home Theatre



X8 (X2)  
Big PA sound in a compact box  
2-way passive, 8"



SB15M (X 2)  
Compact subwoofer, 15"



LA4 X (X1)  
Amplified controller



QM450A  
*Lightweight Active 12" Loudspeaker*



QM18SA  
*Powered Sub with DSP*



QM450A SYSTEM  
*Lightweight Active 12" Loudspeaker*



QM18SA SYSTEM  
*Powered Sub with DSP*



MX601/MX801 MONITORS  
*High-Fidelity Weatherproof Loudspeakers*



QX-300 SERIES  
*Amplifier Commercial Power*



QX4750 BACK PANEL  
*QX Rackmount Amplifier Series*

2 X HPI 5  
*5" High Output Loudspeakers*

HPI25  
*High Power Dual 5" Loudspeaker*

QM1000P  
*Complete Sub/Satellite Amplifier System*

SMALL CORPORATE SYSTEM



S21 DIGITAL MIXING  
CONSOLE

*Dual P-CAP multi-touch screens, 48 flexi-channels, the equivalent of 46 buses and benchmark 96kHz performance*



S21 DIGITAL MIXING  
CONSOLE

*Three 10-inch multi-touch screens, over three banks of 10 faders, and control of 30 channels. 48 flex-channels*



QUANTUM 225 DIGITAL  
MIXING CONSOLE

*Maximum of 72 input channels with 36 busses and a 12 x 12 matrix, all with full channel processing.*



QUANTUM 338 DIGITAL  
MIXING CONSOLE

*Trio of 17-inch, 1000 nit, high brightness multitouch screens. 70 individual TFT channel displays join the floating Quantum chassis with 38 100mm touch sensitive faders laid out in three blocks of 12 fader banks plus two dedicated user-assignable faders, each with high resolution metering.*



SD9 DIGITAL MIXING  
CONSOLE

*96 Input Channels, 48 Aux / Sub-Group Busses, LR/LCR Master Buss, 12 x 8 Full Processing Matrix, 155 Dynamic Equalizers, 48/96kHz Sample Rate.*



**KLANG: FABRIK**

*KLANG:fabrik creates individual immersive in-ear mixes for up to 16 musicians simultaneously. With super low latency and flexible I/O -fabrik elevates every monitoring experience.*



**KLANG KONDUCTOR**

*KLANG:konductor is the most powerful and versatile KLANG processor ever created and heralds a new era of Immersive In-Ear Mixing.*



**KLANG KONTROLLER**

*KLANG:kontroller delivers fast tactile user control of channels, groups and immersive mixing via an intuitive interface.*



**KLANG:QUELLA 19"**

*8 channel Dante XLR breakout box with additional reference headphone amp outputs*



**DMI-KLANG**

*DMI-KLANG is a powerful Immersive In-Ear Mixing Expansion for DiGiCo Consoles and DiGiCo OrangeBox.*



**KLANG: APP**

*KLANG:app is the GUI for all KLANG:processors. Setup, mixing and Signal Placement is all done with one intuitive application.*



### PROTON DUO

*Proton Duo combines a Waves Proton SoundGrid server, an Axis Proton Waves-customized computer, and a built-in network switch.*



### WAVES SERVER ONE-C

*One-C is a custom-designed, optimized DSP unit that relieves your computer of plugin processing.*



### AXIS SCOPE

*Computer optimized to run Waves audio applications. The Waves Axis Scope computer is built from the ground up to deliver maximum stability and performance in Waves SoundGrid systems.*



### TITAN SOUNDGRID SERVER

*Waves' most powerful server ever, Titan allows you to supercharge your mixes with low-latency processing of hundreds of Waves plugins, live or in the studio.*



### SUPERRACK SOUNDGRID

*Built and optimized for speed, SuperRack SoundGrid is a cutting-edge plugin rack for FOH, monitor, broadcast, and AV engineers. Run up to 64 stereo multi-channel racks, through multiple instances of Waves' plugins, with near-zero latency—and with endless customization options.*



**BODYPACK TRANSMITTER  
EW-DX SK**

*Digital wireless bodypack transmitter with 3.5 mm jack connector compatible with Evolution Wireless Digital systems. Rugged metal housing, up to 12 hours of runtime, persistent E-Ink display and charging contacts for in-device charging.*



**BODYPACK TRANSMITTER  
EW-DX SK 3-PIN**

*Digital wireless bodypack transmitter with 3-pin locking connector compatible with Evolution Wireless Digital systems. Rugged metal housing, up to 12 hours of runtime, persistent E-Ink display and charging contacts for in-device charging.*



**HANDHELD TRANSMITTER  
EW-DX SKM**

*Digital wireless handheld transmitter without switch compatible with Evolution Wireless Digital systems. Rugged metal housing with standard capsule interface for a wide range of Sennheiser and Neumann microphone modules. Up to 12 hours of runtime, persistent E-Ink display and charging contacts for in-device charging.*



**HANDHELD TRANSMITTER  
EW-DX SKM-S**

*Digital wireless handheld transmitter with switch compatible with Evolution Wireless Digital systems. Rugged metal housing with standard capsule interface for a wide range of Sennheiser and Neumann microphone modules. Up to 12 hours of runtime, persistent E-Ink display and charging contacts for in-device charging.*



**RECEIVER EW-DX EM 2**

*Two-channel digital half-rack (9,5") receiver for use with Evolution Wireless Digital handheld, bodypack and tablestand transmitters. Extended 88 MHz switching bandwidth, intermodulation-free operation for up to 293 channels with secure AES-256 encryption and redundant power supply via Power over Ethernet (PoE).*



**RECEIVER EW-DX EM 2  
DANTE**

*Two-channel digital half-rack (9,5") Dante®-enabled receiver for use with Evolution Wireless Digital handheld, bodypack and tablestand transmitters. Extended 88 MHz switching bandwidth, intermodulation-free operation [intermodulation-free equidistant channel spacing] for up to 293 channels with secure AES 256 encryption and redundant power supply via Power over Ethernet (PoE).*



**RECEIVER EW-DX EM 4  
DANTE**

*Four-channel digital full-rack (19") receiver with internal PSU and Dante® for use with Evolution Wireless Digital handheld, bodypack and tablestand transmitters. Extended 88 MHz switching bandwidth, intermodulation-free operation [intermodulation-free equidistant channel spacing] for up to 293 channels with secure AES 256 encryption and four modular network ports.*



### EW-DX SK / SKM-S SET - BASE SET

*EW-DX base set consisting of 1 x EW-DX SKM-S (handheld with mute switch), 1 x EW-DX SK (wireless bodypack transmitter), 1 x EW-DX EM 2 rackmount receiver (2 channels) and 2 x BA 70 rechargeable batteries. Microphone capsules are sold separately.*



### EW-DX MKE 2 SET - LAVALIER SET

*This wireless lavalier microphone set consists of 2 x EW-DX SK (wireless bodypack transmitter), 2 x MKE 2 (omni-directional clip-on lavalier microphone), 1 x EW-DX EM 2 rackmount receiver (2 channels) and 2 x BA 70 rechargeable batteries.*



### EW-DX MKE 2 / 835-S SET - COMBO SET

*This combo set consists of 1 x EW-DX SKM-S (handheld with mute switch), 1 x MMD 835 capsule (cardioid, dynamic), 1 x EW-DX SK (wireless bodypack transmitter), 1 x MKE 2 (omni-directional clip-on lavalier microphone), 1 x EW-DX EM 2 rackmount receiver (2 channels) and 2 x BA 70 rechargeable batteries.*



### XSW IEM SET

*The XS Wireless IEM set includes everything you need for an easy start with personal monitoring. Defining new standards for simple, flexible, and reliable wireless in-ear monitoring, this system is designed to help you level up your sound, regardless of your tech experience. Whether a rehearsal or live performance, on a club stage or for a worship service: Benefit from renowned Sennheiser sound and solid pro-grade wireless UHF reliability packed in a convenient and rugged system – letting you focus on playing your best.*



### XSW IEM EK STEREO RECEIVER

*With XS Wireless IEM, you can easily link additional receivers to one transmitter – connecting more band members to a new level of detail. The lightweight bodypack remains unnoticed once clipped on your clothing or belt. You can plug in the included IE 4 in-ear monitors or upgrade to the IE PRO series with the 3.5 mm output.*



### XSW IEM SR STEREO TRANSMITTER

*The XS Wireless IEM transmitter features metal housing designed for durability and can be rack-mounted system or used stand-alone. The clear, backlit menu allows for easy setups even on dark stages. The XLR combo inputs provide flexible cabling options – you can connect anything with a XLR or 6.3 mm (1/4 inch) plug.*



### IE 100 PRO

*Dynamic in-ear monitors for confident monitoring even on the loudest stages. Consistent frequency response in both low and high SPLs. High wearing comfort, even for hours, thanks to an ultra-flat design. With a stage-proof, robust construction.*



### MD 445

*The top model of dynamic Sennheiser microphones sounds impressive thanks to its unparalleled presence and openness. The sophisticated and extensive sound calibration of the dynamic, wired microphone creates noticeably greater proximity to the vocals. W*



MD 435

*Dynamic vocal microphone with nuanced resolution and transparency for a detailed sound. The high-end model MD 435 reproduces vocals clearly and confidently, even in loud, live settings. The spring-mounted capsule, rugged design and hum compensation coil reliably shield it from external influences.*



MM 445

*The dynamic microphone capsule MM 445 is impressive thanks to its unparalleled presence and openness for all vocal types. Its sophisticated acoustic tuning and lightweight aluminum-copper voice coil provide increased proximity and sensitivity.*



EW 100 G4-835-S

*Cardioid, dynamic wireless system for singers or presenters. The first choice for both sound designers and occasional users because of its simplicity.*



EW IEM G4

*Hear anywhere on stage and make your gig an extraordinary experience – not just for your audience, but also for you. Engineered for pro live sound.*



XSW 1-825 / XSW 1-835

*Easy to use all-in-one wireless system for singers and presenters. Rely on a solid transmission with up to 10 compatible channels in a stable UHF band*



E 835

*Dynamic cardioid microphone that projects well and cuts through high volumes on stage. Intended for home recording, semi-pro studios and live sound.*



SKM 6000

*More channels, better transmission performance: intermodulation-free handheld transmitter with maximum spectral efficiency and huge signal reliability. Via the Sennheiser standard capsule interface, compatible with Sennheiser and Neumann capsules.*



SK 6212

*Ultra-light, digital mini-bodypack for discreet but maximum performance on stages during musicals or theatrical performances and broadcast applications. The metal housing is water and sweat-resistant; the exchangeable battery guarantees 12 hours of continuous operation.*



DP7

*7 Piece drum microphone package  
Includes D6, two – D2 dynamic drum microphones, one D4 , i5 ,  
and a pair of ADX51 studio condenser microphones, four D-Vice  
rim mount clips three heavy-duty tension fit microphones.  
Packaged in a foam-lined aluminum road case*



FP7

*7 Piece drum microphone package - affordable excellence  
Contains a combination of f2, f5, and f6 dynamic microphones and the f9  
condenser. Built to withstand the rigors of live stage applications, the Fusion  
Series microphones are also excellent for rehearsal, school, House of Worship, and  
a wide variety of home recording applications.*



OM3

*Multi-purpose vocal & instrument  
dynamic voal microphone*



AP41 OM2

*Wireless microphone System - R41  
diversity receiver with H60/OM2  
handheld transmitter.*



AP62 OM5

*Wireless microphone system - R62 two  
channel true diversity receiver with  
two H60/OM2 handheld transmitters.*



B60

*Wireless microphone component - 64  
mhz bodypack transmitter.*

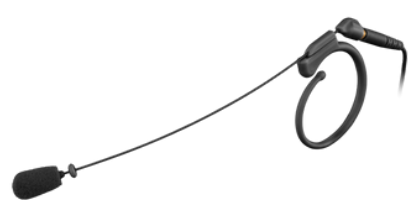

HT7

*Single ear headworn wireless condenser vocal  
microphone for presentation, AV and  
broadcast.*



ADX12 & ADX18

*Miniature gooseneck condenser microphones in  
12 and 18 inch lengths.*

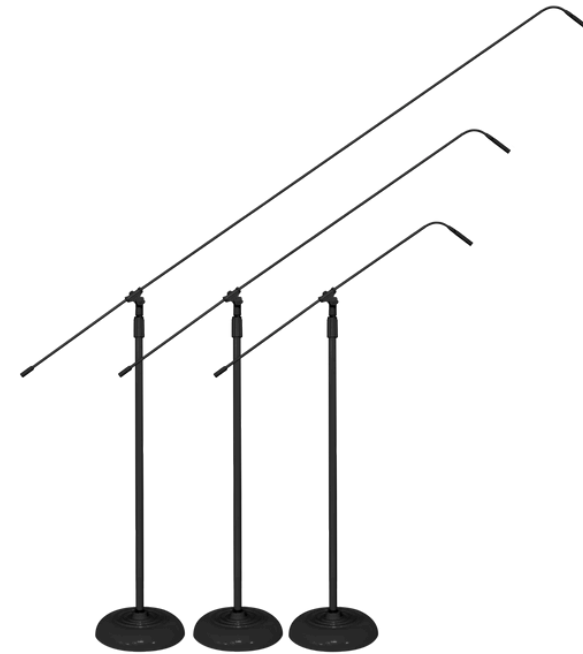
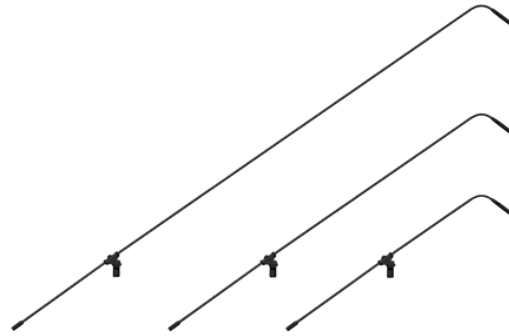

## MICROBOOM SYSTEM

*Multiple length miniaturized condenser microphone boom system.*

The MicroBoom™ System is produced in three lengths: 24", 50", and 84" and comes with a carbon fiber rod compatible with any of The Micros™. Lightweight, able to attach to any microphone stand, the MicroBoom™ is a problem solver for many hard-to-reach miking applications including choir, live theater, and orchestra.

The MicroBoom™ can be used with any of the microphones in The Micros™ series providing a broad selection of pick-up patterns, output levels, and frequency responses. High quality shielded cable is used internally to insure the cleanest audio signal path between the microphone and the bottom of the boom. The stand adapter offers total control over the angle, rotation, and position of the carbon fiber rod by way of a flexible metal gooseneck. The MicroBoom™ provides an ultra-clean, professional, and elegant appearance on stage while providing exceptional performance and portability.

*The MICROBOOM System comes with a carbon fiber boom (24", 50" or 84"), microphone (M1250B, M1250BHC, M1255B, or M1255BHC), clutch assembly, 25' shielded cable and windscreen. Available in white or black finish.*



M3 SERIES

*Tri-element hanging ceiling microphone*



M70 SERIES

*Flush mount high output ceiling microphone*



DN4

*Enhanced onramp fo Dante | AES67*



M3WDK

*Microphone & interface kit for the Dane | AES67 integrated microphone system.*



M70WD

*Flush-mount ceiling microphone for the audix Dante | AES67 Integrated microphone system.*



M63

*Logic-enabled condenser boundary microphone.*



ATS1 SERIES

*Heavy duty shock absorbent table stand with latching on/off switch.*



**UE PREMIER**

*Loaded with 21 drivers per side, these are our most advanced in-ear monitors. Ever.*



**UE 5 PRO**

*The classic UE 5 Pro is a versatile workhorse that provides balanced full-range sound and excellent isolation for any application. With an internal crossover and dedicated drivers for the low and high frequencies, UE 5 Pro is a great in-ear monitor.*



**UE 6 PRO**

*UE 6 Pro provides enhanced low-frequency output for drummers, bassists, electronic artists and DJs who need to feel the full power of their performance.*



**UE 7 PRO**

*To perform your best, you need to be able to hear the nuance in every note. With a focus on the critical midrange frequencies and a tightly controlled bass response, UE 7 Pro provides intimate detail for guitarists, vocalists and other lead performers.*

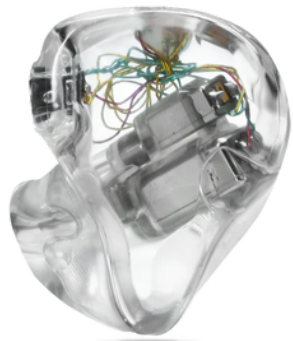

**UE RR**

*Ultimate transparency for critical listening. Recording, mixing, editing and mastering require transparent, neutral sound for best results. Three-way crossover & precision-tuned drivers for the low, mid and high frequencies, UE Reference Remastered provides phase-accurate clarity & detail from 5 to 40,000 Hz.*



**UE 11 PRO**

*With a three-way crossover for unparalleled clarity and dual low-frequency drivers for extra bass reinforcement, UE 11 Pro gives you the best of both worlds.*



**UE 18+ PRO**

*UE 18+ Pro delivers world-class sound consistently at any volume. A four-way crossover and six proprietary drivers deliver increased headroom at all frequencies, bringing out the dynamics of your performance.*



**UE LIVE**

*Made for discerning professionals who need a perfect balance of detail and musicality, Eight precision-tuned drivers reproduce your music with maximum purity and power, while the tour-proof design guards against the rigors of the road.*



DX410-4UP-SYSTEM



HELIXNET PARTYLINE



HELIXNET-BASE-AND-BP



HELIXNET DIGITAL NETWORK  
PARTYLINE INTERCOM SYSTEM



FREESPEAK II DIGITAL WIRELESS INTERCOM SYSTEMS



DX410 DIGITAL WIRELESS INTERCOM SYSTEMS

# ARCADIA®

Now with increased capacity and I.V. Direct™ IP Connectivity

32

FreeSpeak  
IP Transceivers

64

FreeSpeak  
Beltpacks

128

HelixNet  
Endpoints

**4W/2W**

I.V. Direct

Arcadia    LQ Series    Eclipse HX  
SIP    Agent-IC    Station-IC



MINI BODY PACK 2

*In Ear Body Pack with volume control (passive)*



IN EAR STICK

*Pro audio in-ear headphone amp en miniature for use on stage and in the studio*



HARDWIRED IN EAR BELT PACK

*Wired, portable in-ear monitor system – a “classic” product! Hard-wired headphone amp for those musicians whose instrument restrict their freedom of movement (keyboards, drums, percussions, background vocals).*



MINI DI-BOX

*The mini DI-Box with clip can be attached to the belt or instrument strap. Thus the unbalanced signal path is very short which minimizes interferences to the instrument signal. The signal is balanced electronically.*



### HARVEY PRO

*Available in various IO configurations, which are appended to the name, e.g. HARVEY Pro 8x8, HARVEY Pro 16x8 or HARVEY Pro 8x8-DA. In addition to audio signal processing, lighting and media control, HARVEY Pro allows for a flexible response to different market requirements with regard to the number of channels.*



### HARVEY RC12

*A programmable, Ethernet-based wall-mount remote control. RC12 is capable to control presets, audio levels or DMX-lamps and can select channels in a HARVEY device, call up presets or trigger the sending of commands, whether via the serial interface or the IP network, using its 12 freely programmable buttons. All RC12 buttons can be individually customized in their color and brightness.*



### HARVEY RC4

*programmable, Ethernet-based wall-mount remote control. RC4 is capable to control presets, audio levels or DMX-lamps. All RC4 LEDs and buttons can be individually customized in their color and brightness.*



# LED SCREENS & PROJECTION

In recent years, there has been a noticeable and rapid surge in the utilisation of LED panels, from the professional audio visual market to theatre stages.

# NT Series

NT2.6 / NT2.9 / NT3.9W

# Abgen

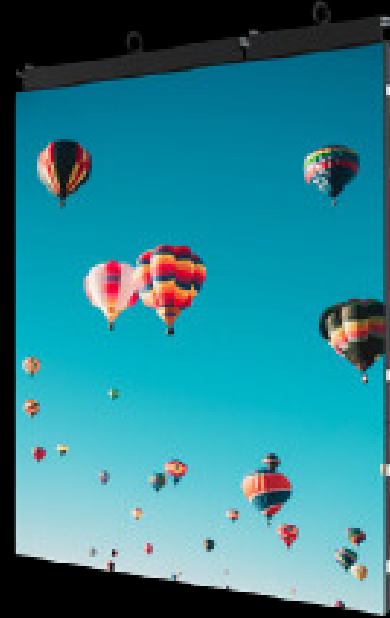

# NOVA STAR



PL2.9 LITE / PL3.9W LITE

Indoor:

PL2.5 Lite / Lite ( Cube )

PL2.9 Lite / Lite ( Cube )

PL3.9 Lite / XL Lite / Lite ( Cube )

Outdoor:

PL3.9W Lite / XL Lite / Lite ( Cube ) >PL4.8W

Lite / XL Lite



ICON C / ICON ULTRAWIDE / ICON SLIM

Absenicon C Standard Series provides an elegant solution that is easy to operate.



NT2.9 / NT3.9W

High brightness, high refresh rate, and creativity are inbuilt in the Neptune Series which offers three models, NT2.6, NT2.9 and NT3.9W, to meet the indoor and outdoor needs of the events industry. The NT3.9W outdoor model of the Neptune Series display can even be configured as stage flooring, simplifying the creation of immersive environments for every events installer.

NX / KL LL / HC / CL

NX series adopts a hidden wiring design for neat look in the back. Flatness adjustment between panels. X/Y/Z axis alignment. Bright and dark lines.

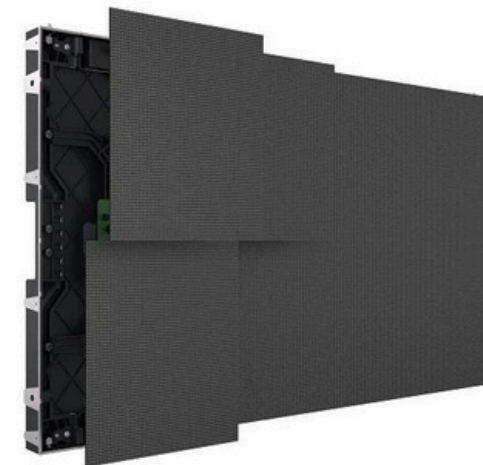

Abjen

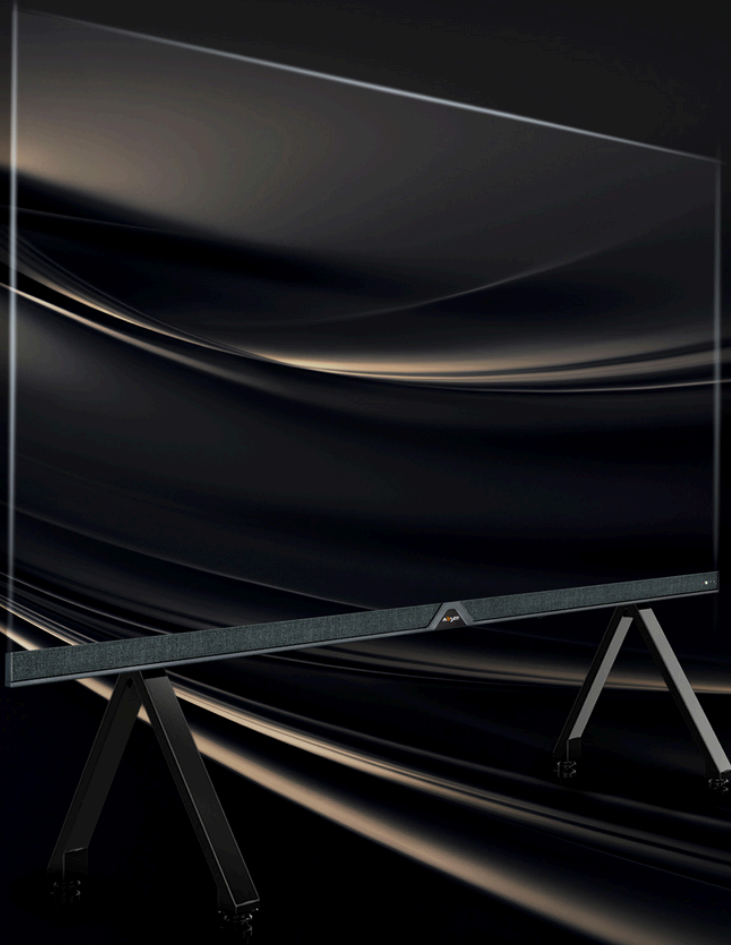

*Absenicon C Series*

Abjen  
Trusted LED Supplier

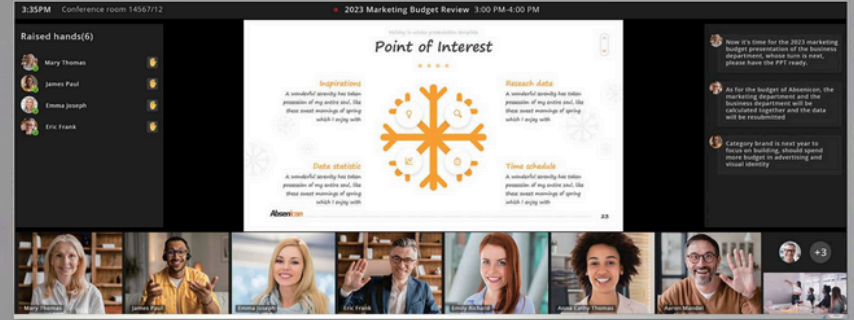

**Absenicon C Ultrawide Screen**

154"/181"/ 208"

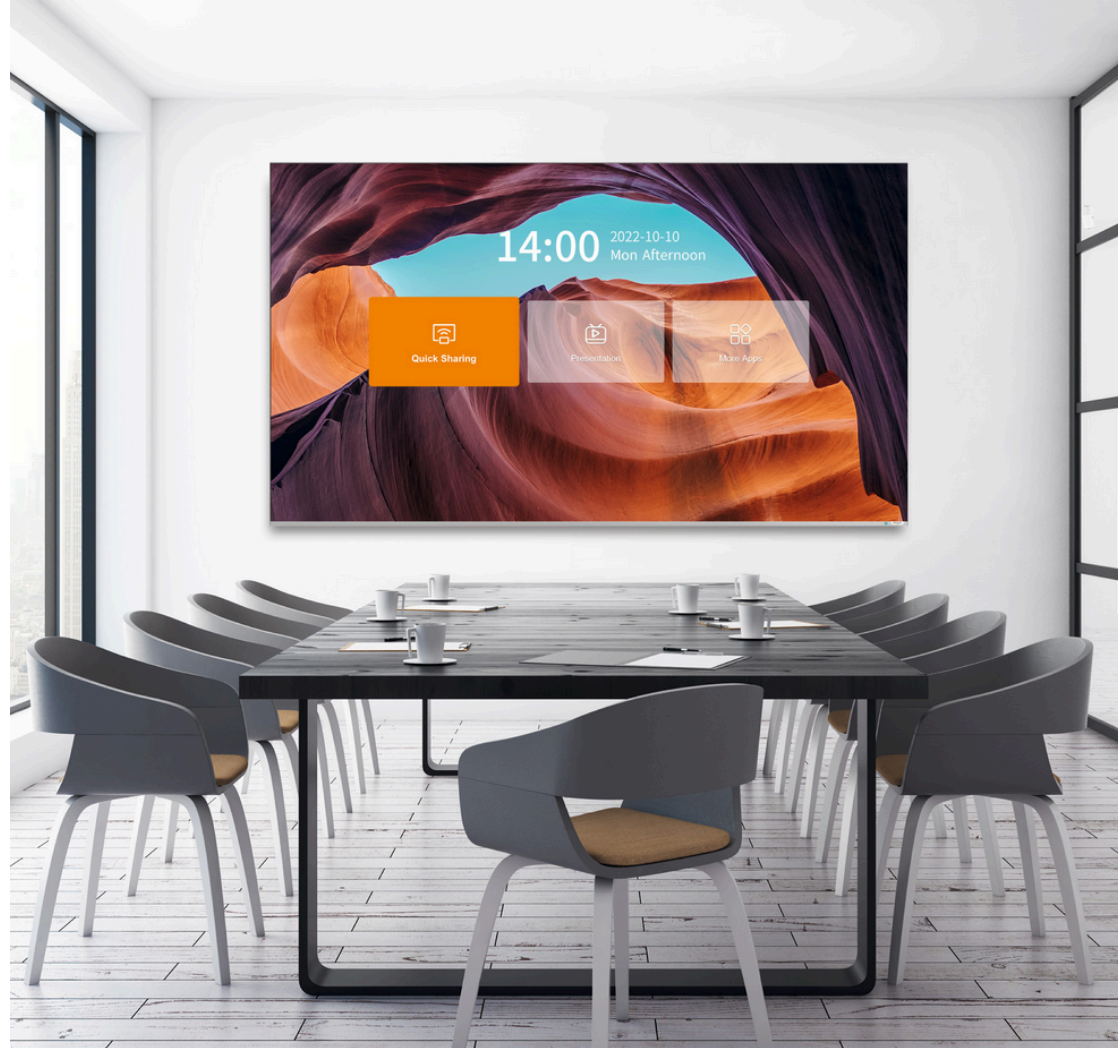

**absen**  
Trusted LED Supplier

 **Absenicon C Slim**

110" 138" 165"

Model	Clear Cobalt	
	CL 0.9	CL 1.2
LED Type	Flip Chip RGB	Flip Chip RGB
Pixel Pitch (mm)	0.95	1.27
Panel Dimensions (WxHxD)/(mm)	610×343×58	610×343×58
Pixel Per Panel	640 × 360	480 × 270
Panel Weight (kg)	7	7
Panel Material	Die-cast aluminum	Die-cast aluminum
Brightness (nit)	1200	1200
Refresh Rate (Hz)	2880	3840
Gray Scale (bit)	14	14
Contrast Ratio	20000 : 1	20000 : 1
Color Temperature (K)	6500	6500
Viewing Angle (H/V) (°)	160/160	160/160
Power Consumption (Max./Avg.)(W/m <sup>2</sup> )	456/152	522/174
Operating Temperature(°C)	-10~+40	-10~+40
Operating Humidity (RH)	10%~90%	10%~90%
IP Rating (Front/Rear)	IP40/IP21	IP40/IP21

\* Shenzhen Absen Optoelectronic Co., Ltd. reserves the right to modify product design, specifications, and parameters without further notice. Photos are used for illustration purpose only as products may differ from these photos. All rights reserved by Shenzhen Absen Optoelectronic Co., Ltd.



In the era of Ultra HD technology, expectations and requirements are high. Customers expect outstanding quality from their LED displays.

Clear Cobalt, is the new generation of display products from Absen. Using several innovative technologies to provide outstanding visual performance versus traditional LED products. The CL series also supports 2K/4K/8K for higher HD display requirements. Producing stunning visuals for professional control rooms, corporate lobbies, TV studio, large conference rooms and luxury living.

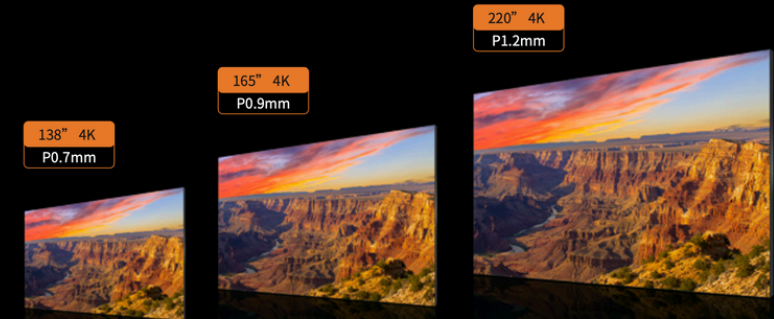

Black Coating Technology



HDR10



Wide color gamut



Flip Chip Technology



High Reliability

# KL Series II

1.2mm | 1.5mm | 1.8mm | 2.5mm



**16:9**  
Golden ratio



**Fine Adjustment**  
Grayscale improvement technology



**HFR+**  
High frame rate mode



**Color Precision**  
Color management technology



**800nits**  
Maximum brightness



**3840Hz**  
High refresh rate



**X/Y/Z axis**  
Six-direction alignment



**Floating connectors**  
Fast installation and maintenance

For all commercial display applications



Control rooms



Retail, shopping malls



Transportation Hubs

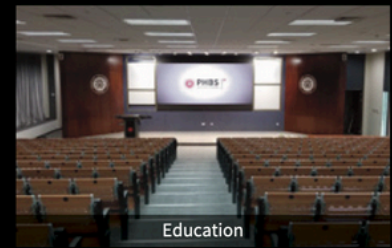

Education

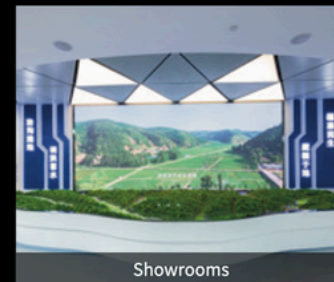

Showrooms



Enterprises



Conference Rooms

# KL Series II

1.2mm | 1.5mm | 1.8mm | 2.5mm



**16:9**  
Golden ratio



**Fine Adjustment**  
Grayscale improvement technology



**HFR+**  
High frame rate mode



**Color Precision**  
Color management technology



**800nits**  
Maximum brightness



**3840Hz**  
High refresh rate



**X/Y/Z axis**  
Six-direction alignment



**Floating connectors**  
Fast installation and maintenance

For all commercial display applications



Control rooms



Retail, shopping malls



Transportation Hubs



Education



Showrooms



Enterprises



Conference Rooms

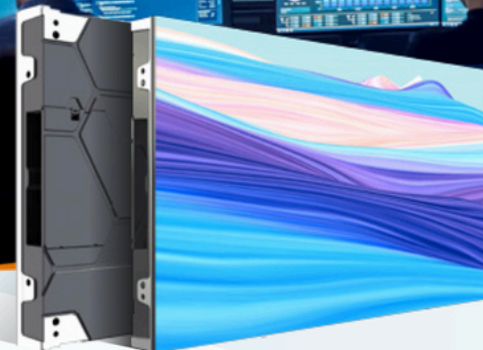

### > New HC Series

The new HC series is a narrow pixel pitch display, featuring stunning HD vividness, lightweight design, and both safety and stability.

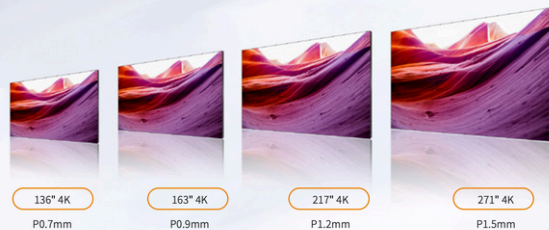

136" 4K

P0.7mm

163" 4K

P0.9mm

217" 4K

P1.2mm

271" 4K

P1.5mm

### > Simple Front & Back Design

Rich detail for an exceptional viewing experience.



**HC II**  
Product

**600x337.5x50mm**  
Panel Dimensions

**5.2KG**  
Weight

**Die cast aluminum**  
Material

# New HC Series

Indoor Narrow Pixel Pitch Display



EC90

All-in-One 8Kx2K video console. 4-channel output includes 2-channel 4K main output and 2-channel 4K auxiliary output, supports customized output resolution, independent output or mosaic output



EC80

All-in-One 4K Switcher. MIG-680 has 1 Program output and 4 AUX outputs. All of them support 4Kx2K@60Hz and customized resolution setting.



MIG-F4-1U SERIESW4000

A single DP, HDMI input supports 4Kx2K@60Hz 4:4:4, easy to achieve large-resolution point-to-point display.



LED-W4000 SERIES

8Kx2K LED Video Processor. Under HDMI output mode, single output supports 4K x 2K@60Hz resolution, can customize the resolution in this range.

Total 2 x HDMI output, single machine supports 8K x 2K@60Hz.



LED-W2000 SERIES

4Kx2K LED Video Processor. 4 x DVI horizontal mosaic, 8K x 1K pixel to pixel and multi picture display



HDMI/SDI CONVERTER

MIG-2134. Supports DVI signals of various resolutions to convert high-definition SDI signals, with clear images, rich colours and more powerful performance.



4K FIBRE EXTENDER

Standard HDMI2.0 port. Support Max. 3840x2160@60Hz. Single-core LC interface; single-mode fiber transmission 2000m; multi-mode fiber transmission 300m

TWO TIME AWARD WINNER



### 8-BAY REVERSIBLE FRAME

*The Theatrixx Reversible Converter system is the natural extension of the award-winning xVision Converter line, now available in a modular rackmount format with the same processing quality and reliability that is the hallmark of the xVision brand.*



### SDI/HDMI BIDIRECTIONAL

*xVision Converter Series  
Introducing the world's first video converters truly designed for the road.*



### HDMI TO FIBER - TRUE1

*xVision Converter Series  
Professional equipment in mission-critical applications is all about reliability and confidence.*



HDMI DISTRIBUTION AMPLIFIER  
1:4 - TRUE1  
*xVision Converter Series*



SDI AUDIO DE-EMBEDDER - TRUE1  
*xVision Converter Series*



**TIERRA+ MK2**

*The go-to for demanding large event production. 4x HDMI or 4x DisplayPort 1.2 Production Outputs*



**BOREAL+ MK2**

*The standard for touring media servers. 4x DP 1.2 or 4xHDMI Production Outputs.*



**KARST+ MK2**

*Unparalleled power and flexibility built into a custom, tour-ready case. 2x DP 1.2 or 2x HDMI output options.*



**MAYON+ MK2**

*2x HDMI output Hippotizer system to effortlessly drive smaller live events and installations. 4K Control outputs for ZooKeeper – 1 x HDMI 2.0 and 1 x DP1.2.*



**AMBA+ MK2**

*A compact and powerful 1U media server. 1x Unlimited Resolution Output on DisplayPort (Supports splitters).*



**NEVIS+**

*The small, yet powerful 1/2 RU Media Server. 1x DisplayPort 1.2 output with EDID Management (Supports splitters).*



**HIPPOTIZER PLAY**

*Hippotizer™ PLAY is a free to download, demo version of the Hippotizer™ V4 software.*



**HIPPOTIZER PREP**

*Pre-program from the comfort of your own PC or laptop. Encode media or program a show with the full host of Hippotizer components.*





### CORIOMASTER2

*Optimized for 4K60 environments and is 8K ready. Display up to 40 4K video windows with no visible latency and up to 56 outputs in a 4RU.*

*Category: tvONE Products*



### CORIOMASTER2

*Optimized for 4K60 environments and is 8K ready. Display up to 40 4K video windows with no latency and up to 56 outputs in a 4RU.*

*Category: Video Wall Processors*



### CORIOMASTER

*Powerful stand-alone 4RU video wall processor for expansive 1080p installations with up to 56 inputs, which can also display up to five 4K video windows, and up to 56 outputs in 4RU.*

*Category: Video Wall Processors*



### CORIOMASTER MINI

*Compact form 1RU processor for medium 1080p solutions with up to 18 inputs, and the ability to add two 4K video windows, and up to 20 outputs.*

*Category: Video Wall Processors*



### AMBA+ MK2

*Ultra-compact, half-width 1RU processor with integrated front button panel for up to 8 inputs or up to 8 outputs in 1080p environments with optional 4K connectivity.*

*Category: Video Wall Processors*



### CORIOGRAPHER SOFTWARE

*Advanced Control Software for CORIOmaster2, CORIOmaster2 LITE, CORIOmaster, CORIOmaster mini, CORIOmaster micro, and CORIOview products.*

*Category: Video Wall Processors*



### CORIOMASTER2 LITE

*CORIOmaster2 LITE 4K Video Processing for small and medium applications available outside of North America.*

*Category: Video Wall Processors*

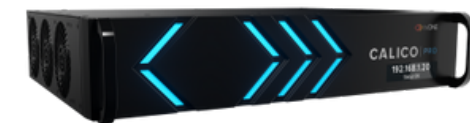

### CALICO PRO

*Coming soon! High bandwidth 2RU video processor based on a fifth generation 4K/8K, 10bit processing engine.*

*Category: Video Wall Processors*



PA 804UL LASER  
PROJECTOR AM 350

*Super-silent technology with the 8,200 lumens  
PA804UL laser projector*



**4K UHD  
READY**

IPA803U

*NEC's PA803U is a 8000-lumen  
widescreen advanced professional  
installation model that appeals  
higher education and corporate  
users.*



PX2201UL LASER

*Delivering rich intense colour through RB laser  
technology, almost equal in performance to a 3DLP  
projector. The ultra-bright 20,500 lumen projection can  
be multiplied using wide interface selection and Edge  
Blending technology supporting two or more projectors  
for wider, larger, even brighter images, whilst  
geometric correction eliminates distortion.*



NEC PA1004UL LASER

*Super-silent technology with the 10,000 lumens.. Featuring  
unprecedented White Point performance, factory pre-  
calibrated for the perfect white, 12-bit colour signal  
processing and wide colour space, with vivid colour  
saturation and contrast levels.*



F80-4K12  
12,000 lumens, 4K UHD, DLP laser phosphor projector



F80-Q12  
12,000 lumens, WQXGA, DLP laser phosphor projector



G62-W9  
9,000 lumens, WUXGA, DLP laser phosphor projector

## BARCO IMAGE PROCESSING

The Barco processors excel in versatility and flexibility. With screen management solutions, you can size the system to the event, not the event to the system! Their link cards allow you to expand your system by linking E2 to E2, S3-4K to S3-4K, or E2 to S3-4K. You can also link the Ex processor to the E2 or S3-4K. This enables easy expansion beyond the standard number of inputs, outputs and layers, minimizing additional external processing or routing to distribute the signals.



E2  
The groundbreaking flagship processors for professional video switching on the largest pixel canvases.

- 16x 4K input and 8x output supported
- Easy show setup and reliable show production
- Flexible layer management



S3  
The more compact processing sidekick for applications that do not require the full capacity of an E2.

- 5x 4K input and 6x 4K output supported
- Compact and modular design
- Easy expansion thanks to interlinking of chassis



EX  
By linking the Event Master expansion unit with other E2 or S3-4K processors you add input and output capacity.

- Add extra switching power to your system
- Simplified cabling and system setup
- Invest only when you need to



# CONNECTORS, CABLES & POWER DISTRIBUTION



**AUDIOJOG PRO 3**

There are 2 rows of 4 LED's corresponding to each of the possible connector pins and one for the screen (or ground) connection. As each pin is activated, the LED's indicate all connections associated with that pin, so that short, open and crossed circuits can be easily found. The LED's also show the possibility of high resistance or leakage connections.



**AUDIOJOG PRO 8**

Audio/Lighting/Network cable tester with single and ended testing, memory and intermittent fault detection.



**AUDIOJOG RACK 19 POWERCON FAN IN BOXED**

AudioJoG Rack 19 powerCON fan in is a cable tester to test standard 18 or 19 wire Socpex cables as well as Socapex plug to 6 powerCON inlet (blue) fan in or spider. Housed in a 3u instrument case with lockable lid and carrying handle.



**AUDIOJOG RACK**

Cable tester for audio cables 19" rack mount



NEUTRIK offers premium copper connectors and cables, innovative fiber optic systems and unique digital network devices.



XLR CONNECTORS



PLUGS

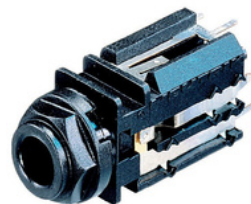

JACKS



PHONO RCA



SPEAKON



OPTICALCON



FIBERFOX



ETHERCON



POWERCON

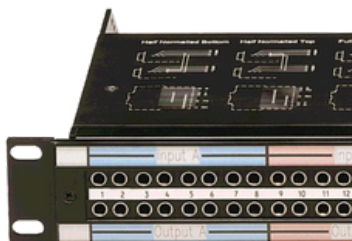

PATCH PANELS



XIRIUM PRO



DANTE INTERFACE



MILAN OEM SOLUTIONS



REAN provides designers of audio, video and lighting products a comprehensive range of connectors featuring ultra-robust, high-reliability designs, that promise unrivalled cost-performance ratios, backed by a truly global supply-chain and experienced regional sales network.



AIR-TIGHTNESS:  
RRX3F-Z-012  
XLR 3 pole female receptacle,  
standard D-shape metal flange  
IP65 rating.



AIR-TIGHTNESS:  
RRX5F-Z-012  
XLR 5 pole female receptacle,  
standard D-shape metal flange  
IP65 rating



AIR-TIGHTNESS:  
RRX5M-Z-012  
XLR 5 pole male receptacle,  
standard D-shape metal flange  
IP65 rating



AIR-TIGHTNESS:  
RRX3M-Z-012  
XLR 3 pole male receptacle,  
standard D-shape metal flange  
IP65 rating



AIR-TIGHTNESS:  
RRX3MF-Z-012  
XLR 3 pole female and male  
combination receptacle  
IP65 rating.



AIR-TIGHTNESS:  
RRX5MF-Z-012  
XLR 5 pole female and male  
combination receptacle  
IP65 rating



Z SERIES  
RRX5F-Z  
5 pole female XLR receptacle with  
D-Size Flange, solder cups and IP65  
protection



Z SERIES  
RRX3F-Z  
3 pole female XLR receptacle with  
D-Size Flange, solder cups and IP65  
protection



Z SERIES  
RRX3M-Z  
3 pole male XLR receptacle with D-  
Size Flange, solder cups and IP65  
protection



Z SERIES  
RRX5M-Z  
5 pole male XLR receptacle with D-  
Size Flange, solder cups and IP65  
protection



Z SERIES  
RCX3M-Z  
3 pole male XLR cable connector  
with IP65 dust-water proof design.



Z SERIES  
RCX3F-Z  
3 pole female XLR cable connector  
with IP65 dust-water proof design.



CONTRIK is a brand of the Neutrik Group and a provider of professional power distribution systems, equipotential bonding systems and premium power cables.



POWER RACKS

*Power Rack Xtreme is a powerful and highly reliable distribution solution for installation in the 19" Rack. It is ideally suited for amplifier rack wiring application.*



POWER RACK XTREME  
CPR16-C2-F7-CB

*1x CEE16A In / Daisy chain, 7 x Schuko Typ F Out.*



POWER RACK  
XTREME CPR16-C2-T6F1-CB

*1x CEE16A In / Daisy chain, 6 x powerCON® TRUE1® TOP & 1 x Schuko Typ F Out*



POWER RACK XTREME  
CPR32-C2-F7-CB

*1x CEE32A In / Daisy chain – 7 x Schuko Typ F Out.*



POWER RACK XTREME  
CPR32-C2-T6F3-CB

*1x CEE32A In / Daisy chain, 6 x powerCON® TRUE1® TOP & 3 x Schuko Typ F Out*

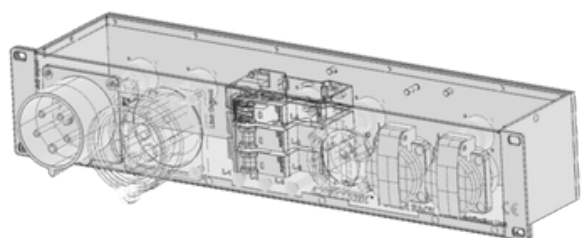

CUSTOMIZATION 19"  
POWER DISTRIBUTION

*Custom configurations are available on request.*



POWER RACK XTREME  
CPR32-C2-F9-CB

*51x CEE32A In / Daisy chain, 9x Schuko Type F Out*



POWER TURTLES

*Lightweight, compact, highly reliable and rugged power distribution and stage-ready "turtle" boxes*



POWER TURTLE XO  
CPVT7RT-M

*1 x powerCON TRUE1 TOP In- 7 x powerCON® TRUE1® TOP Out - Power Meter. Power Turtle Xtreme Outdoor (XO) is a compact distribution solution for mobile outdoor applications where power meter is required.*



POWER TURTLE XO  
CPVT7RT

*Power Turtle Xtreme Outdoor. 1 x powerCON TRUE1 TOP In- 7 x powerCON® TRUE1® TOP Out.*



POWER TURTLE  
XTREME OUTDOOR  
CPT-C2-T6-CB

*1x CEE32A In – 6x powerCON® TRUE1® TOP Out, 6x MCB circuit breakers  
Power Turtle Active is an rugged compact distribution box which features separate circuit protection against the overload (MCB) for of each Out, and popular CEE32A connector for input & daisy chain.*



POWER TURTLE XTREME  
OUTDOOR CPTM-H1-T6

*IN: 1x Harting E16 – OUT: 6x powerCON® TRUE1® TOP*



POWER TURTLE XTREME  
OUTDOOR CPTM-H1-T12

*IN: 1x Harting E16 – OUT: 12x powerCON® TRUE1® TOP*



POWER TURTLE  
XTREME OUTDOOR  
CPTM-S1-T6

*IN: 11x Socapex 419 – OUT: 6x powerCON® TRUE1® TOP*



POWER TURTLE  
XTREME OUTDOOR  
CPTM-S1-T12

*IN: 1x Socapex 419 – OUT: 12x powerCON® TRUE1® TOP*



POWER TURTLE X  
CPTX-T1-T7

*1 x powerCON TRUE1 TOP In- 7 x powerCON® TRUE1® TOP Out - Indoor (IP20)*



POWERSAFE CONNECTOR



POWERSAFE SINGLE  
POLE CONNECTORS



POWERSAFE EARTH  
PANEL MOUNT



POWERSAFE L2 PANEL  
MOUNT



POWERSAFE L3 PANEL  
MOUNT



POWERSAFE NEUTRAL  
CONNECTOR



POWERSAFE L2  
CONNECTOR



POWERSAFE L3  
CONNECTOR



POWERSAFE POWER  
DISTRIBUTION BOX



SOCAPEX PLUGS

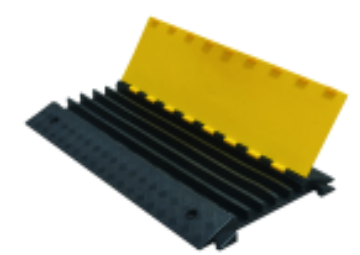

5 CHANNEL CABLE  
GUARD RAMP



DX10  
DI box passive



OT2000 ULTRA LEXIBLE AES & DMX CABLE  
IP65-rated footlight & cable tray  
two individually controlled zones



HDMI 2.1 AOC LINK 8K  
active optical cable  
armoured - plugs with protective caps

**KLOTZ**  
interfaces

wireless

the signal masters

KSH-304RSP patch cable

wireless

the signal masters

KSH-370R patch cable

Jan Hoffmann - Long Distance Calling

Made in Germany

**KLOTZ**  
interfaces

Made in Germany



GUITAR & INSTRUMENT



MICROPHONE & ANALOG



DIGITAL & DMX



CABLE DRUM SYSTEMS



LOOM, ANALOG & DIGITAL



MIDI & USB



JANUS



JANUS TO CEE FORM



DMX CABLE



32 AMP CEE FORM



POWERCON JUMPER



# Power Distribution

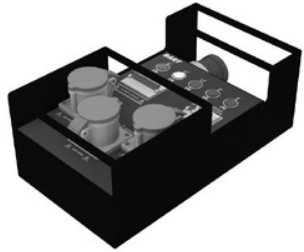

BART 32A 3-PHASE

*Distro*



BEAVIS 32A 3-PHASE

*Distro*



ONLY AVAILABLE WITHOUT EARTH LEAKAGE

BEAVIS II 32A 3-PHASE

*Distro*

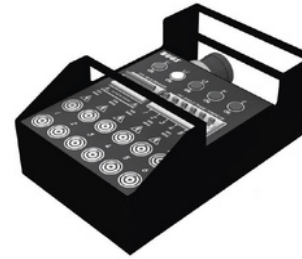

BUGS 32A 3-PHASE

*Distro*



DEWEY 63A 3-PHASE

*Distro*

Earth Leakage version also



FAT ALBERT SOCAPEX

*Distro*



FAT ALBERT II SOCAPEX

*Distro*



HUEY 63A 3-PHASE

*Distro*

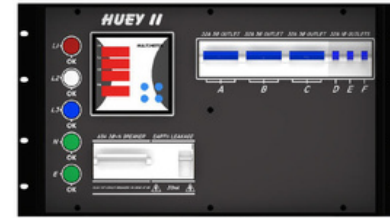

EARTH LEAKAGE VERSION

HUEY II 63A 3-PHASE

*Distro*



LOUIE 63A 3-PHASE

*Distro*



LOUIE II 63A 3-PHASE

*Distro*



LITTLE LOTTA 250A 3

*Distro*



CLIMBING ROPE



ENDLESS ROUND SLING



HARD HAT



MULTI-LEG CHAIN SLING



RIGGING HARD HAT



STAKE CHAIN



STATIC ROPE



STROP



50MM RÄCHET WITH TWISTED SNAP HOOKS



BOW SHACKLES



STEEL WIRE



SAFETY STEEL



HARNES

